

**FORTIAN
OLYMPIAD 2000**

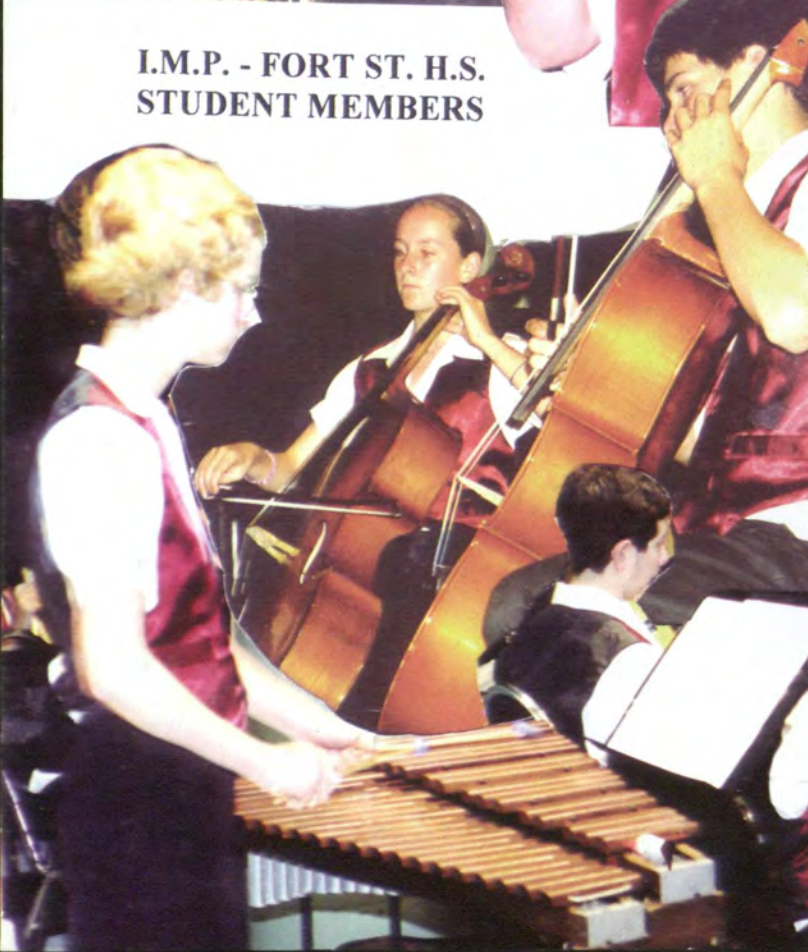



**I.M.P. - FORT ST. H.S.
STUDENT MEMBERS**



The Fortian 2000

Vol.98



Ruby Chui Yr.9

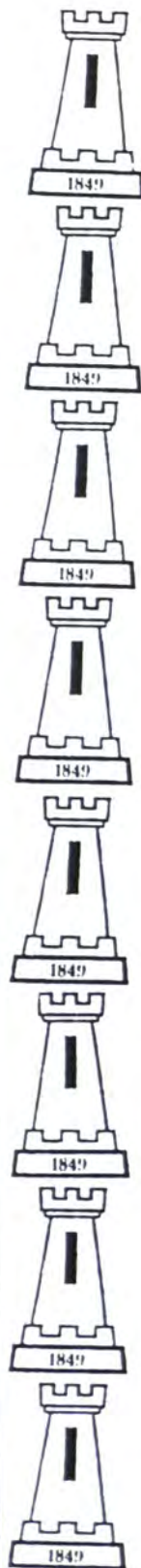
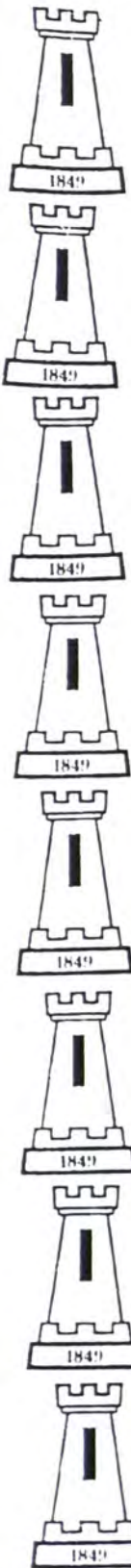

CONTENTS

Principal's Report
Deputy Principal's Report
Speech Day
Year 12
Class of 1946 – 1950
Archives
Year Debating 2000
Year 10 Report
Year 10 Camp
Year 9 Camp
Year 7 Report/Camp
Science Report
I.M.P. Report
History Report
Sport Report
Drama Report
Tournament of Minds
Visual Arts

Careers Report
Australian Business Week
Music 2000
Eifuku Student Visit
M.E.G. – Maths Program
Social Science Report
Legal Studies Report
Constitutional Convention
Michael Kirby's Book Launch
Technology & Applied Studies
Fort Street visit France
Chess 2000
Salvation Army Charity
Class Rolls
Peer Support Members
Staff 2000
Year 12 Farewell



Principal's Report

2000 has been a most exciting year, full of Olympic fever, optimism, planning, curriculum change and wonderful student achievements.

The school council has endorsed the big plan, which focuses on major renovation and refurbishment of Fort Street buildings at hopefully no cost to the school community.

2000 was the year that major changes to the HSC and UAI were implemented. We are very pleased with the number of students who have chosen the challenge of both extension courses in English. A number of students have been accelerated in various subjects and our Computing Studies accelerated Year 10 students gained outstanding results in the 2000 HSC taking a number of the first ten places in the state. Technology continues to offer challenges especially with regard to its use as a learning tool in the classroom. The ACER trial commenced in term four, with ACER providing the school with 30 slim line computers for use across the curriculum. During 2001 the school will be the focus of visits from industry with regard to the trial. Should we find the technology suitable for class use at the end of the trial, the school may purchase the equipment at a discount rate.

There were so many achievements during the year, it is difficult to highlight just a few. I was most impressed by our student leaders who represented the school in so many ways: at the Minister for Education's Awards for Teaching Excellence, the Constitutional Convention, Amnesty International Candle Collection Day, Red Shield Appeal, Legacy, and in the day to day operation of the school. I look forward to working with the student leaders in continuing to raise profile of the student council in the life of the school.

The school's profile is enhanced by the wonderful work of the tutors and conductors of the Instrumental Music Program (IMP), the Drama, Chess, sporting maths enrichment and Summer Hill links programs.

Once gain, student learning was enhanced through overseas trips. The excursion to France has assisted the language learning and cultural understanding of Year 10 and 11 students. Other students visited Potsdam, while students from Potsdam and Eifuku had fabulous experiences at Fort Street.

Our school is indeed fortunate to have such a supportive parent community. My work as principal has been made all the easier by the support of parents who work with the school through a range of bodies, the IMP, the School Council and the P&C.

The first year in a school as principal is always difficult, learning about the school and planning changes that are necessary. My sincere thanks to the staff for their support, and in particular Ms Connell our Deputy Principal; who has tirelessly supported me during the year.

I am happy to report that an additional Deputy will be appointed in the holidays

In 2001 our school plan which has been the result of considerable community consultation will be implemented. It focuses on those issues that the whole school community identified as significant for change. I look forward to sharing with you the School Certificate and HSC results for 2000 early in the New Year.

Roslynn Moxham

DEPUTY PRINCIPALS REPORT

The year 2000 has been a significant one for the school, one year on from the Sesquicentenary celebrated with such energy and excitement in 1999.

From the Deputy Principal's viewpoint the most significant change was the change in the key role of Principal, following the retirement of Mr Lee Carroll at the end of 1999. One of the intriguing questions for me in December and January was who would be leading the school when the new school year began. The answer came the day before school resumed, the new Principal had indeed been appointed but only in the last week of the vacation and would not be able to take up the Fort Street Principalship until she had had appropriate time to clear matters and farewell her own school community. As a result I was asked by the District Superintendent to be the relieving Principal at the start of term one. There is nothing like being prepared!

It was with pleasure that we welcomed Ms Ros Moxham as the new Principal, in mid February. It was clear from our first meeting that here was a person of great energy and professional commitment. She has been an excellent Principal to work with. I would also like to commend the work of Ms Debbie Miniutti in her first year as History Head Teacher at Fort Street, and thank Ms. Zora Neurath for her tireless efforts and significant contribution to the school leadership, as relieving English Head Teacher. The profile of the school's executive has changed markedly over the last two years, (as has its gender balance ...) and while change in management and leadership inevitably presents some anxieties and adjustment issues, the overall feeling is one of commitment and willingness to work towards a strong future for Fort Street in the new millennium. Thanks are due to the executive team and the teaching staff as a whole for the substantial efforts expended in the past year, especially in the context of the introduction of the New HSC, and the ever increasing scrutiny of the performance of selective government schools. Combined with the change in leadership at the top, 2000 has been quite a challenging year for the school.

We have been delighted to witness the continuing achievements of our gifted students who are, after all, the *raison d'être* of our school. At the pinnacle of the achievers is Sascha Morrell, who was the recipient of a Minister Award for academic excellence, as well as being the schools dux in the 2000 HSC topping the state in Ancient History and earning an overall UAI of 100. Other significant achievers at this years HSC have been Leo Sek, who will be the recipient of a Premiers Award for scoring over 90 in every subject in the HSC, as well as Nancy Jiang and Zoe Lyon placed second in the state in German and Economics respectively. Mac Shine and Holly Malaquin were both nominated for Encore at the Opera House in February 2001 for HSC Music. Mowena Wilkins for Artexpress and Chris Parris for Onstage for his exemplary individual performance.

The schools Instrumental Music Program continues to build in excellence and enthusiasm under the professionalism, commitment and energy of Phil Harper and John Ockwell. They make an extraordinary contribution to the development of gifted and talented Fort Street students as well as building a significant public profile for the school. Our thanks to them is profound.

Another significant achievement in 2000 was the group results of our Year 10 Computing Studies class who were accelerated to sit for the HSC in Computing Studies, General. Their results were outstanding and they deserve congratulations for their maturity and commitment in undertaking such a demanding exam experience two years before their age related cohort.

My thanks go to the student population as a whole for their many achievements and willingness to undertake and amazing range of responsibilities and challenges throughout the past year. While the HSC is the very obvious and public aspect of student success there are commendable and important actions taken by the majority of our students on any given day of the year. These range from assisting on Open Day, working as a Peer Supporter for new students, commitment to sporting teams representing the school, public speaking and debating, entering regional and state competitions in academic studies, performing in arts festivals and community events, exhibiting art works and other activities too numerous to mention. These efforts and the required commitment provide the measure of a "quality school".

To the parents who have provided invaluable support for the school in the past year, a sincere vote of thanks. As the work of schools becomes more complex and multi-faceted the contribution of parents becomes more vital and significant.

I look forward to working closely and productively with the school community in 2001 and thank staff, students and parents for their hard work, support and generosity over the past year.

Andrea Connell,
Deputy Principal.

SPEECH DAY

Speech Day is one of the most significant dates in the school calendar, when we take the opportunity to reflect on the achievements of students past and present and enjoy the talents of our musicians and public speakers.

It is 'the one day of the year' when the whole school community can gather in celebration as well as renewing past friendships and reliving shared experiences.

This year we have been pleased to have as our Speech Day Guest Speaker, Professor Barbara Gillam of the UNSW Psychology faculty.

Professor Gillam was a key member of the Sesquicentenary Fortians Debating team which posed such serious (though unsuccessful) challenge to our school debating team at last May's Sesquicentenary week celebrations.

Professor Gillam delights audiences with her humour and wit and we were pleased to have her accept our invitation to speak at Speech Day 2000.

Many thanks to Professor Gillam, the Fortians and friends of the school who make Speech Day such a special occasion.

Andrea Connell
Deputy Principal

1999 HSC FORTIAN AWARDS

GRACE BROWN (<i>Premier's Award</i>)	MARGARET CHI
ANDREW TANG	JACK TEIWES
HUY PHAM	NANA FRISHLING
NANCY TCHOU	PETER HARTLEY
PETER LEE-CHEN	EFFIE KLIPPAN
JOEY QUOC NGUYEN LE	ANNA VAN
THOMAS JACKSON (<i>Premier's Award</i>)	SARAH JOHNSON
MINH PHAN	SANTHI CHALASANI

1999 — YEAR 12

- GRACE BROWN** The Ada Partridge Prize for Dux (aeq); The Francis Killeen Memorial Prize for the Best Student proceeding to the University of Sydney; The Herbert Percival Williams Memorial Prize for the HSC Question on Shakespeare; The Judy Levi Prize for Modern Languages; The Charles Harrison Memorial Prize for English (3Unit)(15th in the State); The Ron Horan Prize for German (3Unit)(1st in the State)
- ANDREW TANG** The Ada Partridge Prize for Dux (aeq); The Constance Frith Memorial Prize for the Best Student proceeding to the University of NSW; The Hermann Black Memorial Prize for Japanese (3Unit)(14th in the State)
- HUY PHAM** The Fanny Cohen Prize for 3rd in the HSC; The Laurence Goddard Prize for the Best Student studying Mathematics at University; The Denis Austin Prize for Mathematics (4Unit)(10th in the State); The Dr Bradfield Prize for Physics;

- THOMAS JACKSON** The Kilpatrick Memorial Prize for the Best Student entering the Faculty of Economics at Sydney University; The Terry Glebe Prize for the Best History Student studying History at University; The Annie Turner Prize for English and History; The James Baxendale Prize for English (2Unit); The Evelyn McEwan Rowe Prize for Ancient History (3Unit)(1st in the State); The Harold Jones Prize for Modern History (2Unit)(1st in the State)[aeq]; The Prize for Visual Arts (2Unit)
- NANCY TCHOU** The 1925-29 Girls' Prize for the Best Student entering the Faculty of Law; The Prize for Legal Studies (2Unit)(3rd in the State)
- KHAI QUANG NGUYEN** The Ron Smith Memorial Prize for the Best Student entering the Faculty of Dentistry; The Prize for Mathematics (2Unit)(18th in the State)
- SANTHI CHALASANI** The John Hunter Prize for the Best Student entering the Faculty of Medicine
- JOEY QUOC NGUYEN LE** The John Hopman Prize for the Best Student studying Engineering at University
- THURKA KUHAN** The Anne Weston Memorial Prize for Mathematics (3Unit)
- KATE VAN DYKE** The Dr William Gailey Prize for Biology (24th in the State)
- SOPHIE HIGGINS** The Emily Cruise Prize for Modern History (3Unit)
- SARAH JOHNSON** The Sir Bertram Stevens Prize for Economics (3Unit)
- FILIP KIDON** The Joseph Taylor Memorial Prize for Geography (3Unit)
- TERENCE CHU** The Michael Kirby Prize for Legal Studies (3Unit)
- MIRIAM MAFESSANTI** The Frederick Bridges Memorial Prize for French (3Unit)(14th in the State)
- EFFIE KLIPPAN** The Frederick Burtenshaw Prize for Latin (3Unit)
- DENNIS SINGH** The Gail Salmon Memorial Prize for Japanese (2Unit)
- PAULINE MAN** The Olga Sangwell Prize for Music (3Unit)
- JAMES LANE** The Val Lembit Prize for Drama (2Unit)(3rd in the State)
- BENN O'DONNELL** The Boys' Classes of '40 and '41 Prize for Computing Studies (3Unit)
- DANNY FORD** The Thomas Cooke Memorial Prize for General Studies
- ANNA VAN** The Prize for English (2Unit General); The Prize for Ancient History (2Unit)(5th in the State); The Prize for Food Technology (3Unit)
- ROBERT LAWTHOR** The Prize for Science (4Unit); The Prize for Engineering Science (2Unit)(2nd in the State)
- JACK TEIWES** The Prize for Visual Arts (3Unit); The Fortian Prize for HSC Achievement in Ancient History (3Unit)(10th in the State)
- LINDA FERNANDEZ** The Prize for Science (3Unit)
- PETER LEE-CHEN** The Prize for Economics (2Unit)
- HERINA LEE** The Prize for Geography (2Unit)
- MARGARET CHI** The Prize for German (2Unit)
- ALEX MCGUIRK** The Prize for Latin (2Unit)
- JUSTIN TSEUI** The Prize for Computing Studies (2Unit)
- DAVID ARCIDIACONO** The Prize for Food Technology (2Unit)

1999 — YEAR 11

- JING JING LI** The Lilian Whiteoak Prize for Dux; The David Verco Prize for Mathematics (3Unit); The P&C Association Prize for Physics; The Elvie Selle Prize for Chemistry; The Prize for General Studies.
- THU HA NGUYEN** The Lodge Fortian Prize for General Proficiency (2nd); The Prize for Economics; Certificates for Mathematics (3Unit), Chemistry, Biology and Legal Studies
- SASCHA MORRELL** The Old Girls' Literary Circle Prize for English; The Prize for Ancient History; The Prize for Music 2 Unit Related; Certificates for Modern History and Visual Arts.
- BETTY CHANG** The James Baxendale Memorial Prize for Proficiency in English (2nd); The Prize for Legal Studies
- ALEXANDRA ARNERI** The Warren Peck Prize for Modern History; Certificates for English and Ancient History
- HELEN JIN** The Catherine, Janet and Pauline Calver Prize for

7. **DAVID NG** The Institution of Engineers, Sydney Division, Prize for Engineering Science
8. **JULIA BRITTON** The Prize for Visual Arts; The Prize for Drama; The Prize for Food Technology; Certificate for Ancient History
9. **JEE HYUN KIM** The Prize for Science (4Unit); The Prize for Photography
10. **NANCY JIANG** The Prize for German; Certificates for Mathematics (3Unit), Chemistry and Computing Studies
11. **MARY LENTROS** The Prize for Mathematics (2Unit)
12. **PETER HEY CUNNINGHAM** The Prize for Science (3Unit)
13. **GOHAR YAZDABADI** The Prize for Biology
14. **JOCELINN KANG** The Prize for Latin
15. **JACK PREST** The Prize for Music 2Unit Course 1
16. **MAURIZIO STEFANI** The Prize for Computing Studies
17. **TAMARA PEARSON** Certificates for English, Mathematics (2Unit) and Geography
18. **ANNA McILWAINE** Certificates for English and Science (3Unit)
19. **GEORGINA MORRIS** Certificates for English and Modern History
20. **LEO SEK** Certificates for English and Legal Studies
21. **MATTHEW LOH** Certificates for Mathematics (3Unit) and Economics
22. **VICTOR CHANDRA** Certificates for Mathematics (3Unit) and Economics
23. **GARETH IVORY** Certificate for English
24. **JUDY KA-LING CHAN** Certificate for English
25. **NICHOLAS FALKINDER** Certificate for Mathematics (2Unit)
26. **ADRIK KEMP** Certificate for Mathematics (2Unit)
27. **RHYS HEARNE** Certificate for Science (4Unit)
28. **KER ZHANG** Certificate for Physics
29. **STEPHEN LE** Certificate for Physics
30. **FEI YU** Certificate for Physics
31. **ALAN GAO** Certificate for Chemistry
32. **THOMAS COSTA** Certificate for Biology
33. **PETER BOZYM** Certificate for Modern History
34. **DANIEL FAIRFAX** Certificate for Geography
35. **RUI YI** Certificate for Economics
36. **UMA AGGARWAL** Certificate for Legal Studies
37. **CECILIA NG** Certificate for German
38. **MADUSHINI BAZIL** Certificate for Latin
39. **VERITY GILL** Certificate for Visual Arts
40. **HOLLY MALAQUINN** Certificate for Music 2 Unit Related
41. **ZOE RYAN** Certificate for Drama
42. **NICHOLAS OSBORNE** Certificate for Music 2 Unit Course 1
43. **LIAM RYAN** Certificate for Engineering Science
44. **ELIZABETH LEE** Certificate for Food Technology
45. **CHARLES HUYNH** Certificate for General Studies
46. **MICHELLE ROLDAN** Certificate for Photography
12. **STEPHANIE LOW** The Prize for French
13. **MATTHEW JOHNSON** The Prize for Latin
14. **THOMAS KEANAN-BROWN** The Prize for Drama
15. **HAIDEE WONG** The Prize for Wood Technics
16. **ANDREW SEDLACEK** The Prize for Technical Drawing
17. **ERIC CHOI** Certificates for Mathematics, Science, Geography and Computing Studies
18. **MITHILESH DRONAVALLI** Certificates for Science, Commerce and Asian Social Studies
19. **DUC HO** Certificates for Mathematics and Visual Arts
20. **LAUREN TARR** Certificate for English
21. **NIVEN VANMALI** Certificate for English
22. **LINA JANG** Certificate for English
23. **ALEXANDER VITLIN** Certificate for English
24. **JI-YOUNG LEE** Certificate for Mathematics
25. **YI-CHING ZHAO** Certificate for Mathematics
26. **GUY RAGEN** Certificate for History
27. **TYRON WONG** Certificate for History
28. **MARK BARBER** Certificate for History
29. **CLANCY YEATES** Certificate for History
30. **WENDY TU** Certificate for Commerce
31. **SAM WAKS** Certificate for French
32. **JORDI RUDELLE-GRIEG** Certificate for French
33. **EAMON FENWICK** Certificate for German
34. **SEAN CARRITT** Certificate for Latin
35. **CHENG XIN YANG** Certificate for Japanese
36. **CAMILLA MARGOLIS** Certificate for Visual Arts
37. **PRASHAN RATNAKUMAR** Certificate for Computing Studies
38. **DAVID SUN** Certificate for Electronics Technics
39. **GERRARD SERISIER** Certificate for Wood Technics
40. **VIKNESH VIJAYENTHIRAN** Certificate for Technical Drawing
41. **VICKY KAN** Certificate for Food Technology

1999 — YEAR 9

1999 — YEAR 10

1. **LEANNE CHEN** The Judge Redshaw Prize for Dux; The Major-General Fewtrell Prize for English and History; The Dr William Gailey Prize for Proficiency in Science (2nd); The Bishop Kirkby Prize for Australian History; Certificate for English
2. **ANNA ZHENG** The Molly Thornhill Prize for General Proficiency (2nd)
3. **BASIA SLUSARCZYK** The University of Sydney Year 10 Academic Excellence Award; The Joseph Taylor Memorial Prize for Geography; The Prize for Food Technology; Certificate for Science
4. **JESSICA AU** The Emily Mouldsdale Prize for Science; The Prize for Japanese; The Prize for Visual Arts; Certificate for Mathematics
5. **HOLLY PHILIP** The James Baxendale Memorial Prize for English; Certificate for Drama
6. **KEITH TANG** The Prize for Computing Studies; The Prize for Electronics Technics; Certificate for Commerce
7. **ALICE CHEN** The Prize for Commerce; Certificates for Science and Geography
8. **ARWEN CROSS** The Prize for Asian Social Studies; Certificates for Science and Geography
9. **LIAM TONG** The Prize for Music; Certificate for Computing Studies
10. **PARIS RAMRAKHA** The Prize for German; Certificate for Music
11. **ANUJ GOEL** The Prize for Mathematics
1. **SHERYL SOO** The 1994 Year 12 Prize for Dux; Certificates for English, Geography and Music
2. **DAVID HELSTROOM** The Dr William Gailey Prize for Science; The Prize for Computing Studies; The Prize for Electronics Technics
3. **DAVID COLLITS** The James Baxendale Memorial Prize for English; The Prize for Latin; Certificates for Science, History, Geography and Wood Technics
4. **TOMMY CHEN** The Prize for Mathematics; The Prize for Geography; Certificates for Science and Commerce
5. **AVA LAM** The Prize for History; The Prize for French; Certificate for English
6. **GEORGE NG** The Prize for Technical Drawing; Certificates for Mathematics, Science and Commerce
7. **AMELIA ROBERTS** The Prize for Asian Social Studies; Certificates for Science and History
8. **NIKKI PENG** The Prize for Japanese; Certificates for Science and Commerce
9. **SUSAN HOE** The Prize for Commerce; Certificate for Mathematics
10. **JULIANNA DANG** The Prize for Visual Arts; Certificate for History
11. **PAUL YOUNG** The Prize for Music
12. **EMILY IRVINE** The Prize for Drama
13. **ALEX STUART** The Prize for Wood Technics
14. **ELISE CHEN** The Prize for Food Technology
15. **NEHA GOEL** The Prize for Textiles and Design
16. **ZAINEB DE SOUZA** Certificates for History and Visual Arts
17. **MARIAN LESSLIE** Certificates for History and Computing Studies
18. **HOWARD YEAN** Certificates for Latin and Computing Studies
19. **ALISHA WONG** Certificate for English
20. **NAOMI BEN DAVID** Certificate for English
21. **JOSEMALENE RUAYA** Certificate for English
22. **SARAH HO** Certificate for Mathematics
23. **TIMOTHY SAM** Certificate for Mathematics
24. **MING REN** Certificate for Mathematics
25. **ANN TSUEI** Certificate for Commerce
26. **WILLIAM BROOK** Certificate for Asian Social Studies
27. **LAURA CORNEY** Certificate for French

28. **STEPHEN CHAU** Certificate for Japanese
29. **JIMMY HE** Certificate for Japanese
30. **HANNAH KIM** Certificate for Visual Arts
31. **PATRICK LUNNEY** Certificate for Drama
32. **LEON SHEN** Certificate for Electronics Technology
33. **MICHAEL NGUYEN** Certificate for Technical Drawing
34. **WILLIAM NGUYEN** Certificate for Technical Drawing
35. **GEOFFREY STEWART** Certificate for Food Technology
36. **CATHERINE SANTANGELO** Certificate for Textiles and Design

1999 — YEAR 8

1. **ENOCH LAU** The 1953-57 Boys Prize for Dux; The Prize for Geography; Certificates for English, Mathematics, History, Japanese, Visual Arts, Music and Design and Technology
2. **GINA DANG** The Bishop Kirkby Prize for History; Certificates for English, Mathematics and Design and Technology
3. **ALEXANDRA PARKER** The James Baxendale Memorial Prize for English
4. **JENSYN LUC** The Prize for Mathematics; The Prize for German
5. **WILLIAM FIGGETT** The Prize for Latin; Certificate for Visual Arts
6. **JIN YANG QIAN** The Prize for Japanese; Certificate for Mathematics
7. **JESSICA BROOKS** The Prize for French; Certificate for Geography
8. **CLAUDIA HUSIN** Certificates for English and German
9. **YUN WANG** Certificates for English and Design and Technology
10. **ZUO HUANG** Certificates for Mathematics and Japanese
11. **ANGELA WEN** Certificates for Geography and Design and Technology
12. **STEFANIE WONG** Certificates for Geography and Design and Technology
13. **RUBY CHIU** Certificates for French and Visual Arts
14. **CHRISTINA LAM** Certificates for Visual Arts and Design and Technology
15. **VIRGINIA TANG** Certificate for English
16. **JOHNNY ZHANG** Certificate for Mathematics
17. **HARRIET JOHNSON** Certificate for History
18. **MICHAEL THORNE** Certificate for History
19. **KATHY NGUYEN** Certificate for Geography
20. **MINDY DING** Certificate for Geography
21. **TINA NGUYEN** Certificate for French
22. **MAX WANG** Certificate for Japanese
23. **WILLIAM HEY-CUNNINGHAM** Certificate for Latin
24. **CHIARA BIANCHINO** Certificate for Visual Arts
25. **WILLIAM WONG** Certificate for Visual Arts
26. **TY WOOD** Certificate for Visual Arts
27. **KAVITA BEDFORD** Certificate for Visual Arts
28. **MELISSA ELLINGWORTH** Certificate for Music
29. **MATTHEW LEE** Certificate for Music
30. **AMY BAO** Certificate for Music
31. **DAVID DZIEDZIC** Certificate for Music
32. **CAL McGUIRK** Certificate for Design and Technology
33. **DANG THUAN HO** Certificate for Design and Technology

1999 — YEAR 7

1. **STESON LO** The Alma Hamilton Prize for Dux; The Class Prize for 7T
 2. **EDMUND SULLIVAN** The James Baxendale Memorial Prize for English; The Major-General Fewtrell Prize for English and History
 3. **CHONG XIE** The Dr William Gailey Prize for Science
 4. **AMBER WILCOX** The Dr George Mackaness Prize for History
 5. **PAUL HUA** The Prize for Mathematics
 6. **ALISON KAYE** The Prize for Geography
 7. **ELWIN CROSS** The Prize for Visual Arts; The Class Prize for 7R
- THE CLASS PRIZES FOR YEAR 7**
- | | |
|---------------------------------|-------------------------|
| 7F JOYCE CHAN | 7T CHARLENE KO |
| NANCY SHEN | JESSICA BREWSTER |
| 7O BRONWYN OVERS | 7I AIMEE CHAU |
| 7R MYSTERY BERNAL-DELLER | KRISTINA ERZIKOV |

1999 — SPECIAL AWARDS

1. **RACHEL STEIN-HOLMES** The Rona Sanford Pepper Prize for Service; The Year 12 1976 Prize for the Best All Round Contribution to the School
2. **THERESA McSPEDDEN** The Charles Christmas Prize for Scholarship and Service; The Phillip, David and Robert Lindsay Prize for Debating
3. **NICK LUCCHINELLI** The Old Boys Union Prize for Scholarship and Service; The Raymond and Frank Evatt Memorial Prize for Australian History
4. **GARETH IVORY** The John Hills Memorial Prize for Leadership and Service (Peer Support)
5. **ELAINE CHUI** The Major Isador Sender Memorial Prize for Service
6. **KATE GOUDIE** The Ladies Committee Prize for School Service
7. **PHOEBE HAYLEN** The Elizabeth Cayzer Prize for the President of the SRC
8. **CAROLINE MALCOLM** The Elsie Ferguson Prize for Consistent Service to the SRC
9. **SARAH JOHNSON** The Girls of 1964-1969 Prize for Commitment to the School Community
10. **STEPHEN ECHT** The Boys of 1950-1954 Prize for Commitment to the School Community
11. **THOMAS JACKSON** The Principal's Prize for the Most Outstanding Individual Achievement of the Year - 1st in the HSC in two subjects
12. **PETER HARTLEY** The Caltex Best All Rounder Prize
13. **ANDREW BISHOP** The Reuben F Scarf Prize for Commitment
14. **ALEX McGUIRK** The John Patterson Memorial Prize for Literary Criticism
15. **JACK TEIWES** The Kath O'Shanassy Prize for Writing in Any Category
16. **MELISSA ELLINGWORTH** The Raymond Sly Memorial Prize for Music
17. **JAMIE CAMERON** The Bruce Leonard Memorial Prize for Outstanding Achievement in Music
18. **PAUL YOUNG** The David Anthony Prize for Contribution to Music
19. **HOLLY PHILLIP** The June Anthony Prize for Contribution to Music
20. **SUZANNE CARTWRIGHT** The Instrumental Music Program Prize
21. **JAMES LANE** The Liberty Jools Prize for Originality in the Arts
22. **NICK CURNOW** The Fortian Prize for the Best Individual Performance in the Performing Arts
23. **ZOE RODWELL** The Fortian Prize for Achievement in the Performing Arts
24. **SASCHA MORRELL** The Fortian Prize for Achievement in the Arts
25. **FRANCISCA GAN** The Young Achievement Australia, Business Skills Program Prize

1999 SPORTS PRIZES

1. **SARAH JOHNSON** The Jan Stephenson Prize for Senior Sportswoman; The Most Outstanding Girl in Cross Country
2. **THOMAS HOLYOAKE** The Johnson Memorial Prize for Senior Sportsman
3. **CAROLINE GRANDJEAN-THOMSEN** The Jan Stephenson Prize for Junior Sportswoman; The Most Outstanding Girl in Athletics
4. **LIAM TONG** The Johnson Memorial Prize for Junior Sportsman; The Most Outstanding Boy in Athletics
5. **ANNA McILWAINE** The Sports Pit Prize for Outstanding Achievement in any One Sport - Diving
6. **TOBY SINCLAIR** The Fort Street Rugby Club Prize for Junior Rugby Player of the Year
7. **MONICA TICE** The Most Outstanding Girl in Swimming
8. **PARNEL McADAM** The Most Outstanding Boy in Swimming
9. **JESS McGUIRK** The Most Outstanding Boy in Cross Country
10. **KEELY McNAMARA** The Fortian Prize for Achievement in Sport - Rowing

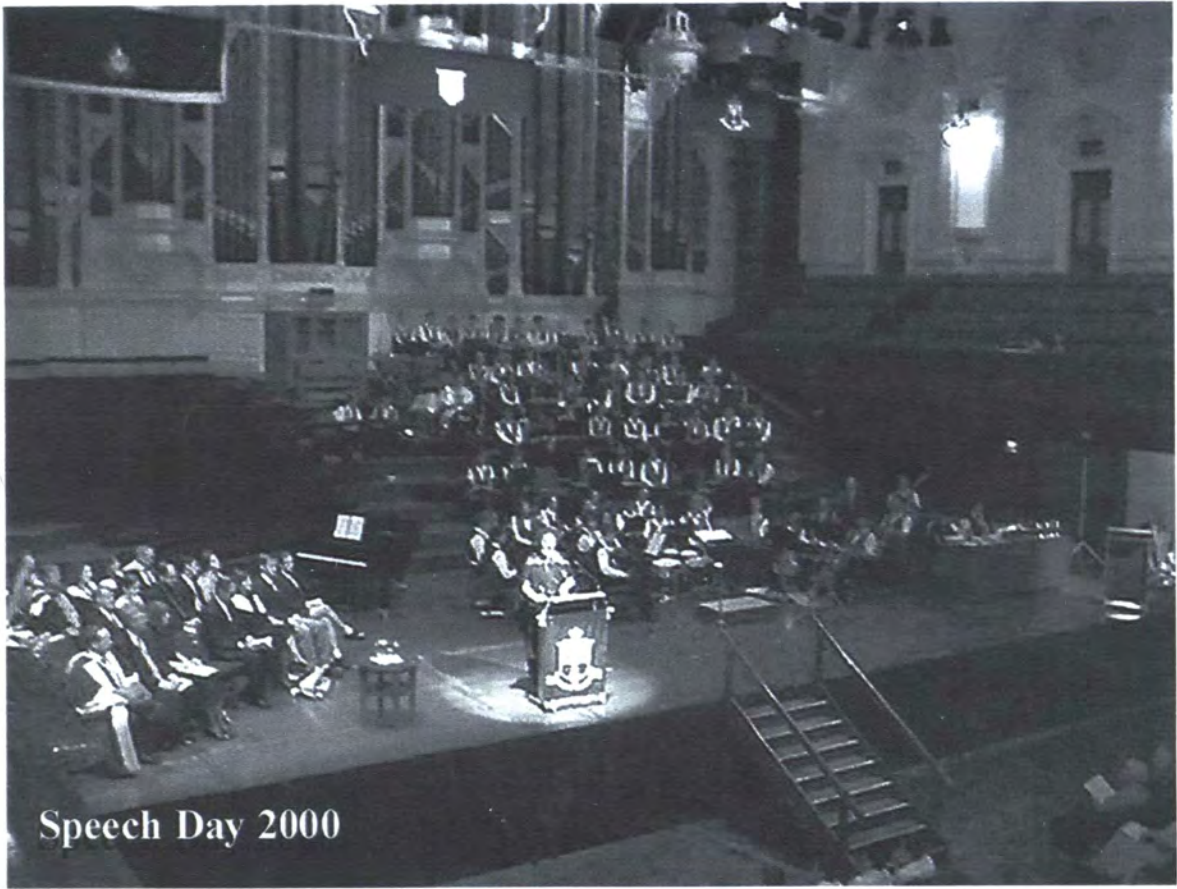

Speech Day 2000



Thomas Jackson celebrates his Premier's Award for Excellence with Ms. Ros Moxham (Principal) and Ms. Andrea Connell (Deputy)



Premier Bob Carr presents Grace Brown With The Premier's Award for Excellence.

YR. 12 PRIZE WINNERS 1999

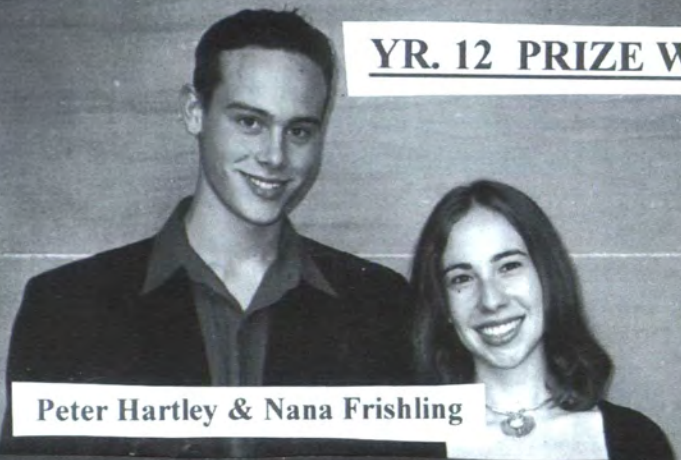

Peter Hartley & Nana Frishling

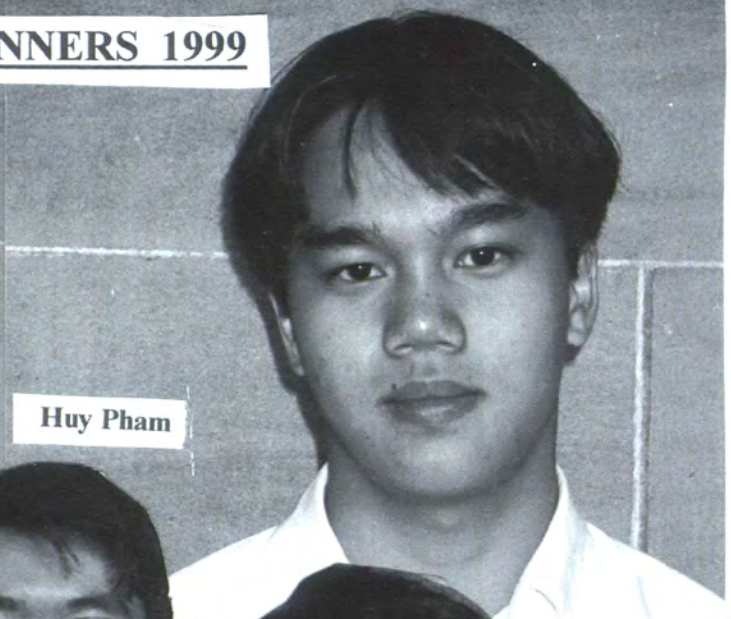

Huy Pham

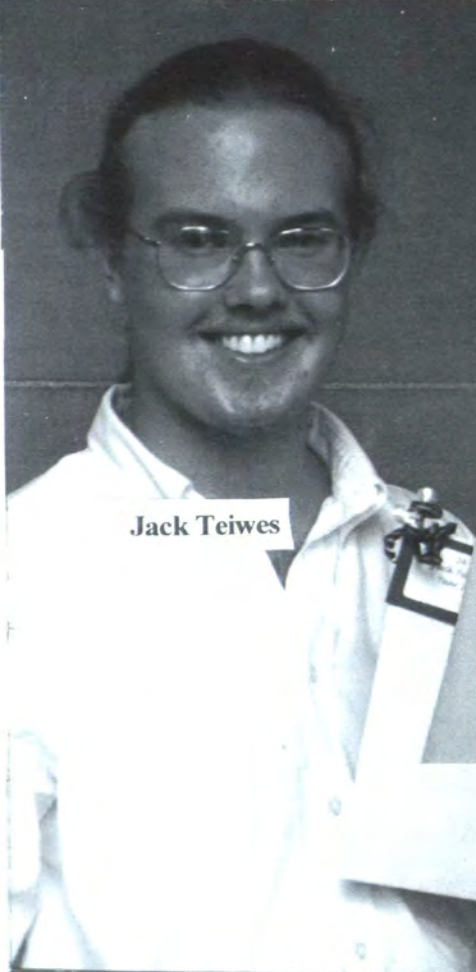

Jack Teiwes

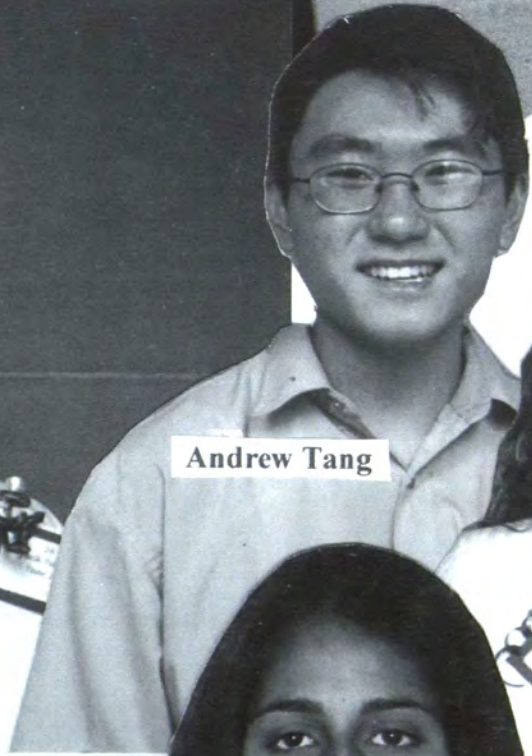

Andrew Tang



Miriam Mafessanti



Thurka Kuhan

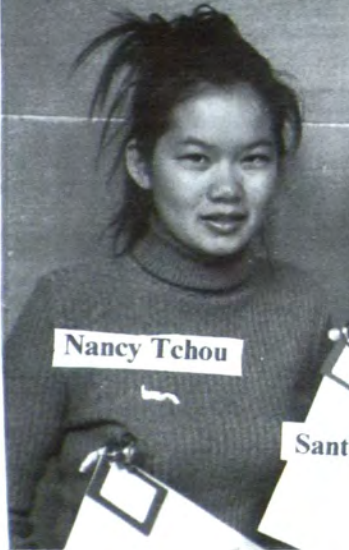

Nancy Tchou



Santhi Chalasani



Justin Tseui

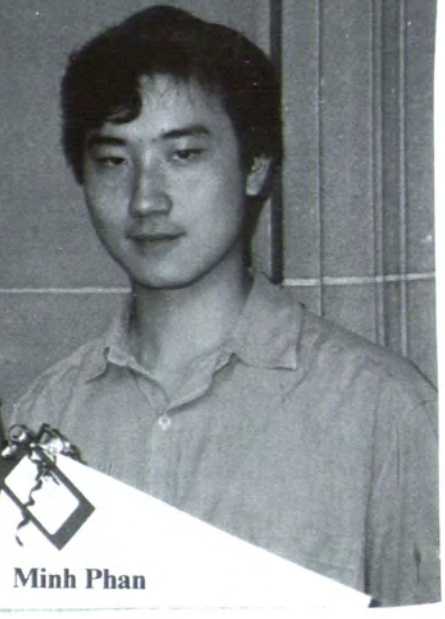

Minh Phan

YR. 12 PRIZEWINNERS 1999



Joey Quoc Nguyen Yr.12



Anna Van Yr.12



Sophie Higgins Yr.12



James Lane Yr.12

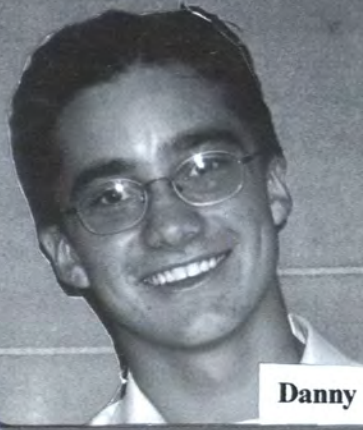

Danny Ford Yr.12

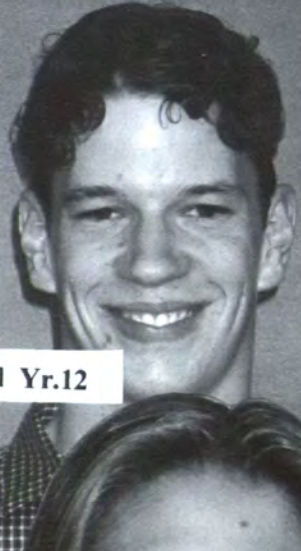

Ben O'Donnell Yr.12



Sarah Johnson Yr.12

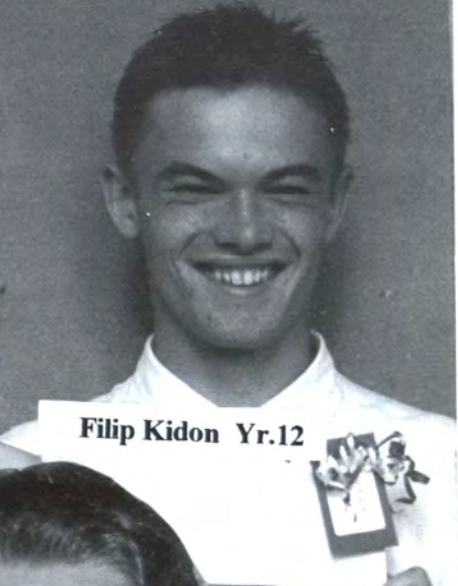

Filip Kidon Yr.12

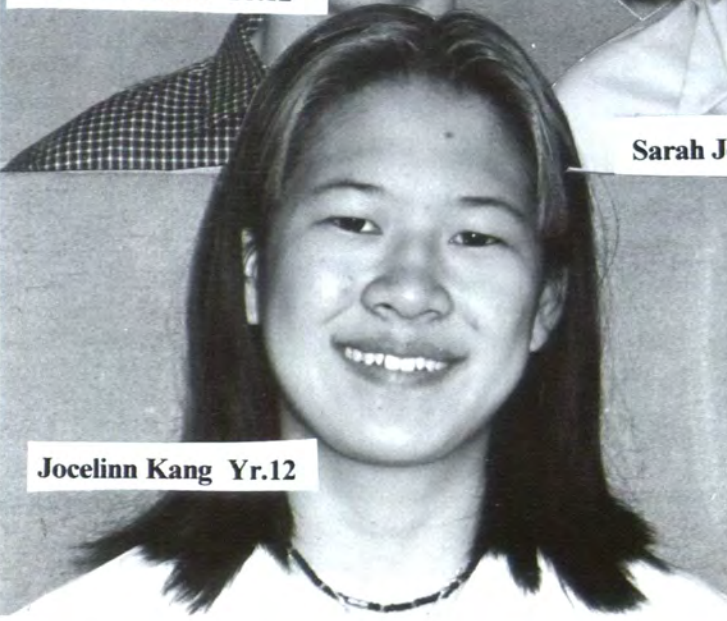

Jocelinn Kang Yr.12

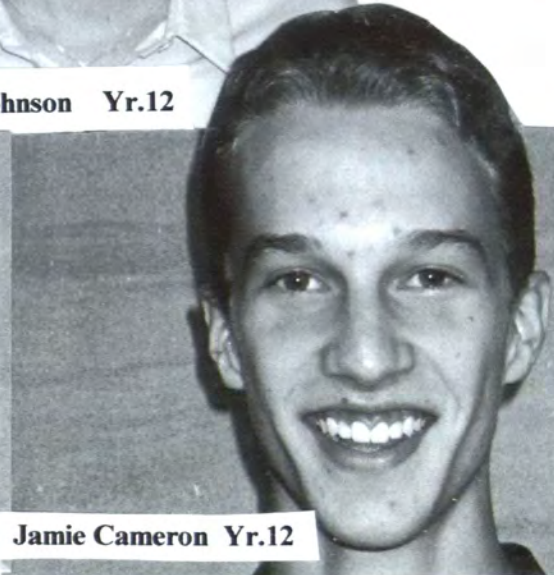

Jamie Cameron Yr.12

PRIZE WINNERS 1999



Holly Philip & Basia Slusarczyk Yr.10

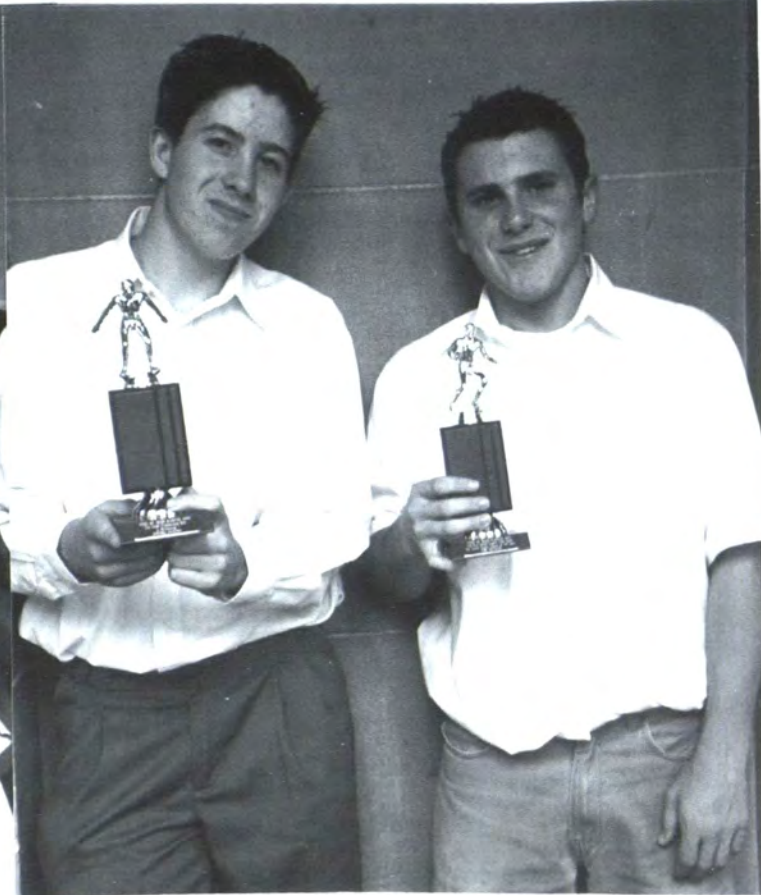

Parnell McAdams Yr.10 & Toby Sinclair Yr.9



**Caroline Grandjean-Thomsen
& Liam Tong Yr.10**



Jess & Alexandra McGuirk

PRIZE WINNERS 1999



Yr.10

Back row: Andrew Sedlacek, Tom Keenan-Brown,
Matthew Johnson, Stephanie Low.
Front row: Anuj Goel, Liam Tong, Keith Tang



Ava Lam Yr.9



Enoch Lau Yr.8

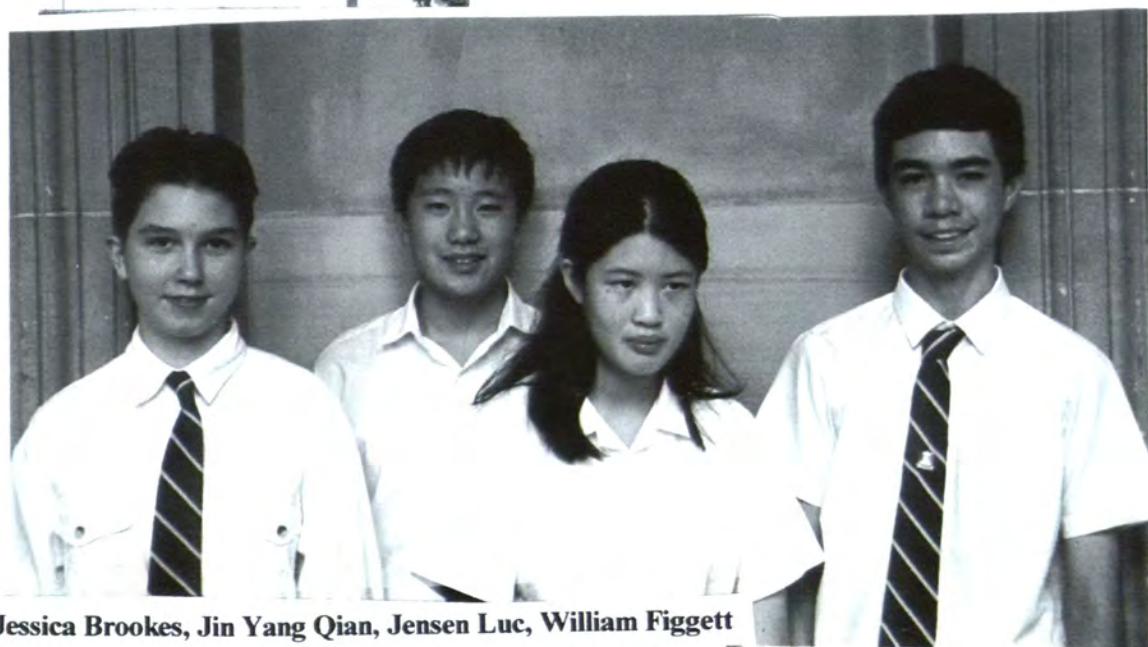

Jessica Brookes, Jin Yang Qian, Jensen Luc, William Figgett

YR. 12 REPORT

A Teacher's Perspective

For you it is the end of thirteen years of school education and, for most, six years at Fort Street. It is amazing how quickly the time has gone.

I can remember reluctantly taking the job as your Year Adviser after Lee Wells, your Year 7 Adviser left and I can clearly remember the sea of cute little faces the first time I approached the masses.

For some of you school has been smooth sailing – for the high fliers who seem to make school and study seem a breeze – but for others there have been considerable hurdles. For some it has been serious hard work, while others take a slightly more laid back approach.

But whatever the situation, for most it is the end of a very important stage of our lives. You will leave the relatively protective environment of Fort Street to make your futures in the world.

'Year 12 – 2000' is an inclusive title but within your cohort there are 158 individuals with their own goals and aspirations, talents, ideas and personalities. There have been outstanding academic achievements by many of you and, in particular, the names of Sasha Morrell, Leo Sek, Matthew Loh, Jing Jing Li and Zoe Lyons come to mind for their performances in the lead up to the HSC.

Many of you have made your mark in the sports arena and congratulations must go to Anna McIlwaine and Keely McNamara and Steven Turner for their exceptional achievements. Others have been prominent in the areas of Drama and Music. I was very impressed with the Drama students on the evening of their performances in preparation for the HSC practical examination, and Mac Shine and Holly Malaquin should be thrilled with their nomination for Encore due to their HSC music exam performance.



You have all left something of yourself that is valued by the school. Thanks and gratitude must go to those who devoted time and effort on many occasions to help the school both during school hours and in your own time.

Others have given enormous amounts of time to the school. Through the SRC, and Elaine Chui and David Ng come to mind. David deserves particular mention for his success in winning a World Scholarship to study in Hong Kong, beginning September, 2000. Others such as Gohar Yazdabadi, Mary Lentros and Charmaine Tam have worked tirelessly to raise money for your formal and to produce the yearbook, and you should be thankful to them. Of course, there are the multitude of you who will be remembered for just being you.

I do wish you all the best in your future careers and hope you will always remember Fort Street High with fondness. Never forget you will always be Fortians.

Warren Griffith
Year Adviser



Jack Prest Yr.12
'Mutes with Sensitivity'

FORTIANS FROM THE CLASS OF 1946 - 1950

April 6 provided an opportunity for current Fortians to hear the 1950's perspective. Seventy-seven Fortians from the class of 1946-1950 returned to celebrate 50years since leaving school.

They presented an honour board which will be used to acknowledge outstanding achievements across all areas of the school, and will focus on achievements of students 1975-2000. The board was presented by John Butt, Captain of 1950.

Dr. Fenton Sharpe, former Director General and Fortian of the class of 1950, gave the address. The special assembly was capably chaired by James Wright and Jacqueline Wong Yr.11.

Fortians of 1950 were overwhelmed by the quality of the concert band performance, and the reception they received from our students as an audience at the assembly.



ARCHIVES

After the excitement of The Sesqui Year, The Archives noticeably quietened down. There have been very few additions to the archives and the number of enquires has also dropped off.

This year has, however, been quite busy for me. I spent a few months trying to finalise the work, begun and almost finished by Ron Horan for the School's War Memorial Board. I am in awe of the enormous amount of research done by Ron in an effort to get the memorial list of names as accurate as possible.

After numerous visits to the Victoria Barracks and the Hyde Park War Memorial, I have finally narrowed it down to two names as yet unconfirmed. Well over 60 new names have been added and all names of Fortians who made the supreme sacrifice in war, from the Boer War to Vietnam, will be placed on the new War Memorial Board and dedicated this year.

Also, in my capacity as School Archivist, I researched the names of Fortians who achieved quite significantly in a wide range of areas in the last twenty years or so and I believe the Principal will dedicate this Honour Board in 2001.

I have enjoyed my first year as the School's Archivist. Until September, 1999 I had been Assistant Archivist to Ron Horan, who lived and breathed Fort Street. Since October, 1999, I have endeavoured to follow in Ron's footsteps, but they are big steps.

**Terry Glebe
School Archivist**

YEAR 11 – 2000

The second last year of school, and the pressure was on for us to perform. We had all the expectations and no textbooks. Thanks Bob Carr. Despite this, the grade performed remarkably well (with a few exceptions of course!).

The P.D Camp was promised, hyped up and didn't disappoint apart from the work, the weather and the good (very) old Collaroy food and of course sleep was optional.

The Year 11 Informal was a cruise on the harbour during August and was easily the highlight of the year for 10 whole minutes, until the after-party began. Remember that ????? Huge thanks to Jo Lin and Otto for those. It was great.

Also thanks to Tiara and others in the SRC for organising the inaugural trip to the Blood Bank and thanks to those who donated. You did us proud.

And we shouldn't forget our grade's sporting excellence. Just recently some guys from our grade formed a cricket team, gained the support from Rick "The Don" Damelian and are now " finding their feet " in the fifth grade competition.

The year 2000 was the year of the Olympics and again several of our grade excelled as they performed in the opening and closing ceremonies to a packed stadium and T.V. audience of billions. Well done!

So all in all, 2000 was a successful year in Year 11's history. God help us in Year 12.

Sean Carritt.



Richard Logge & James K. Wright

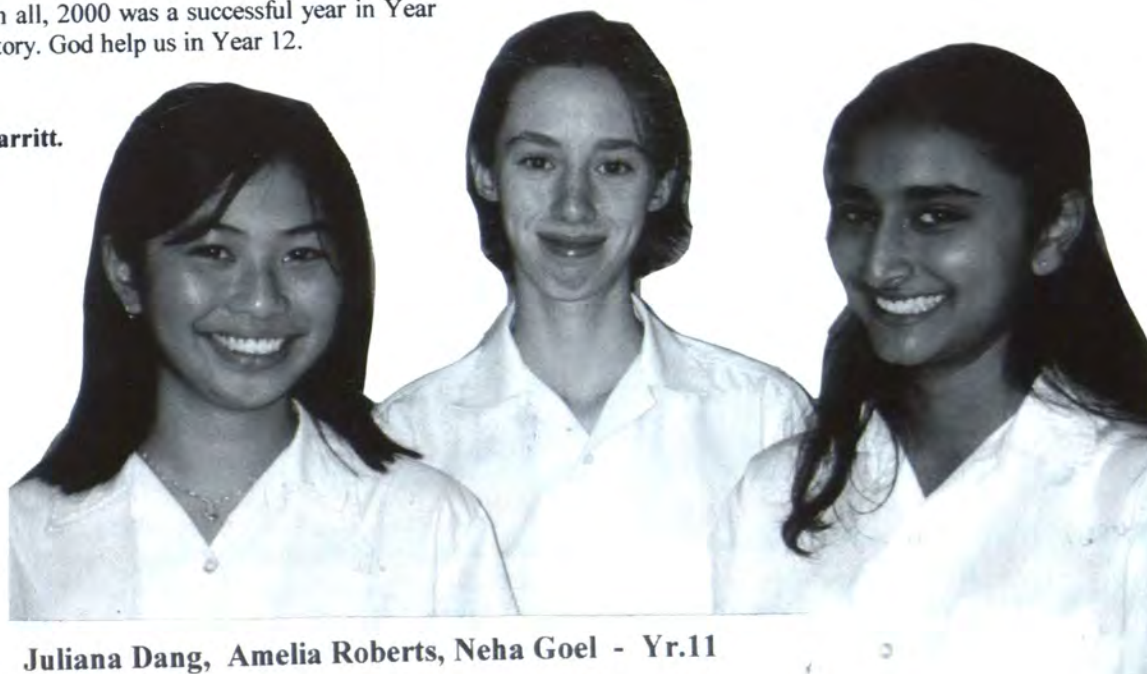

Juliana Dang, Amelia Roberts, Neha Goel - Yr.11

DEBATING - 2000

Another great year for Fort Street Debaters. Our 3 interschool competition teams this year were:

Commonwealth Bank Junior:

Andrew Ta, Elise Chen, Emily Irvine, Sheryl Shoo, Anarag Verma, Zaine de Souza, Jenny Grey and Jacqueline Parker. All from Year 10. Our team is depicted in the photograph below..

Karl Cramp:

Sean Carrit, James Wright, Holly Phillip and Laura Hartley- Year 11.

Hume Barber/E.S.U:

Kelly McNamara, Thomas Costa, Joel Bedford and Thu Ha Ngyuen -Year 12

Both of our Year 11 and 12 Teams won their zone competitions and made it through to the regional semi-finals but sadly Year 10 were knocked out in controversial circumstances. However this disappointment was overcome when Andrew Ta was asked to audition for the Sydney South East Team. Andrew was chosen for the team which went on to be runners up in the Junior State Debating Championship at the University of New England in Armidale on November 27th to 30th 2000.

Well done Andrew!

Special thanks also to Ms. J. Martin who looked after Year 10 team and Ms. K. McDonald who looked after the Year 12 team this year.

Meanwhile junior debating has also prospered during the year. A keen group of the Year 7 and 8 students have met each Monday lunch throughout the year to learn new skills and just to have fun debating. The Year 9 debaters under the stewardship of Enoch Lau (Yr. 9) competed in a round robin competition culminating in a grand final in last term.

All in all it has been a satisfying year, F.S.H.S. is very fortunate to have so many talented speakers who are so enthusiastic about debating.

Mrs M Hosking Debating Co-ordinator



- Back row:** Keeley McNamara, Anarag Verma, Joel Bedford, Andrew Ta, Thomas Costa.
- Middle Row:** Ms. M. Hosking, Zaine de Souza, Jenny Gray, Sheryl Soo, Thu Ha Nguyen, Ms. K. Macdonald.
- Front row:** Laura Hartley, Sean Carrit, Elise Chen, Emily Irvine, James Wright, Holly Phillip.

REPORT ON YEAR 10

It is with great sadness that I write, what will be, for me, my last Student Adviser's Report. I had, of course, hoped to see my wonderful Year 10's through to the finish of their secondary schooling but this was not to be. However, I am leaving them in the excellent care of Marilyn Ireland who, for the last four years, has been the best Assistant Student Adviser possible. She has worked above and beyond the call of duty to help me with the many and varied facets of the Student Adviser's work.

I could always discuss with Ms Ireland, any students who were causing concern and she was always ready to listen and offer some caring and common-sense advice. She also got to know who all of the students were almost as quickly as I did by helping me with the interviewing of all Year 7 students.

I would like to thank Ms Ireland very much for all her help and advice over the past four years. It has been greatly appreciated by me and by the students. I would also like to wish her luck for the next two years. Of course, I will still be closely following the fortunes of all the students and will be getting regular updates about their progress.

I don't think anyone has ever been in any doubt over my feelings for this wonderful group of students. Ever since they entered the school in Year 7, I believed, and still believe them to be one of the best and nicest groups of students to go through the school and I will miss them more than words can possibly say.

Of course, some students found the maturing process a little more difficult than others and may therefore have found the path they trod a little more tortuous than it need have been. However, I firmly believe that all students are now keen and willing to make a commitment towards making the next two years the best and most rewarding of their school life.

One thing I always try and urge all students to do before they leave Fort Street is to make a positive contribution and put something back into the school. I realise, of course, that most of the people have, in their four years, made many, many wonderful contributions to the school in the areas of Academia, Music and Drama, Sport, Debating, Maths and Science, SRC, Cultural Exchanges, Chess, Tournament of the Minds, Sesquicentenary,

On behalf of the school I would like to acknowledge and thank you for all your hard work and effort in these areas.

Congratulations to the following people for their achievements in Year 10:

Student Representative Council

To our Student Representatives for 2000 and 2001. Phoebe Haylen (Vice President), Victor Frankowski, Simon Johnson, Nicole Sutton, Sheryl Soo, Caroline Grandjean-Thomsen, Patrick Lunney, Nina Pollack, Alfred Shiu, Emily Irvine, Juliette Mitchell, Milton Chia, and Igor Butorac.

Sport

To Toby Sinclair, Nick White, and Ben Ryan for their selection in the Northern Suburbs Zone Rugby team.

To our Cross Country placegetters: Caroline Grandjean-Thomsen, Nicole Sutton, Elise Chen, Jenni Gray, Andrew Birdsall, Arun Nadesan, and Nick White.

To our Zone Cross-Country Champions: 16 Years - Caroline Grandjean-Thomsen, Laura Corney, Sheryl Soo, Andrew Birdsall, Simon Johnson, Igor Butorac, and 15 Years - Nick White.

To our Swimming Age Champions: 15 Years - Nick White and Amelia Roberts, and 16 Years - Patrick Lunney, Nicole Sutton, Caroline Grandjean-Thomsen, and Jacqueline Parker.

To Zone Swimmers: Patrick Lunney and Nick White.

To Igor Butorac, selected to represent Northern Suburbs Basketball Association in the 2000 Sydney Junior Championships.

To Alfred Shiu, Victor Frankowski and Grant O'Donnell who coached the Girls Open 15's Basketball teams.

To Igor Butorac who broke the school 16 Years Boys High Jump record.

REPORT ON YEAR 10

To the Zone Champions selected to represent the Zone at the Regional Athletics Carnival - Andrew Birdsell, Igor Butorac, Caroline Grandjean-Thomsen, Bob Jang, Ava Lam, Grant O'Donnell, and Nick White.

To our Zone Champion Open Boys Cricket Super 8: David Collits, Arun Nadesan, Jay Kathavate, Alex Stuart, Anurang Verma, and Andrew Birdsell.

To our Zone Champion Open Boys Netball: Igor Butorac, Kyo Soung Choi, Simon Johnson, Andrew Ta, Patrick White, Anton Trees, Rory Dufficy, and Allan Sun.

To our Best and Fairest in Summer Sport: Michelle Moroney (15's Basketball), Jacqueline Parker/Tracey Ying (Open Softball), Caroline Grandjean-Thomsen (Open Touch), Laura Corney (15's Touch), Arun Nadesan (Open Cricket), Sameer Chowdhury (15's Cricket), Igor Butorac (Open Netball), Boyu Zhao (15's Volleyball), and Kevin Tran (15's Touch).

Maths and Science

To our Macquarie University Cyber Challenge Finalists: Janet An, Tommy Chen, Colin Ding, and Daniel Do.

To our participants in the University of Sydney Shadowing Program: David Helstroom, Alish Wong, Zaine De Souza, Sarah Ho, Sameer Chowdhury, and Edwin Mah.

To our 2000 Maths Challenge successes: Tommy Chen, Catherine Feng, and Janet An (High Distinctions), Louis Huyanh and Sarah Ho (Distinctions), Thomas Huynh and Felix Hong (Credits).

To our Australian Schools Science Competition successes: Tommy Chen, Davy Lei, Timothy Sam, William Brook, Derek Yeung, and Stephen Bernard (High Distinctions).

To our Australian Mathematical Olympiad Committee (AMOC) Intermediate Challenge participants - Tommy Chen, Colin Ding, Brian Diep, George Ng, Catherine Feng, Stephen Bernard, and Ming Ren. From this competition Stephen Bernard and Geoge Ng have been chosen for the 2000 NSW AMOC Correspondence

To Tommy Chen for receiving a Credit Award in the 2000 Australian Olympiad.

To Tommy Chen and Louis Huynh for receiving certificates in the UNSW 39th Annual Schools Mathematics Competition.

Drama and Music

To Patrick Lunney and Emily Irvine who auditioned for the NSW State Drama Ensembles and were successful in reaching 2nd Round "Call Backs".

To Phoebe Haylen who participated in the Secondary Choral Concerts at the Opera House and sang a beautiful solo and who also participated in the Opening and Closing Ceremonies at the Pacific School Games.

To Elise Chen and Emily Irvine who sang an arrangement of "I Can See Clearly Now" at the Annual Performing Arts Night. This night also included monologues by Patrick Lunney and Emily Irvine, the Saxophone Quintet which included Laura Corney, Caroline Grandjean-Thomsen, Nick White and Alex Bryant-Smith, and Colin Ding making his solo debut as a trombonist, accompanied by Paul Young.

To Paul Young who also represented Fort Street as a soloist at the Metropolitan South-East Music Festival at the Opera House.

Chess

To Edwin Ma, Captain of the Intermediate Chess Team.

Cultural Exchanges

To Ava Lam, Amelia Roberts and Victor Frankowski who billeted German Exchange Students from Potsdam.

To Alex Bryant-Smith, Sahra Behardien, Jonathan Chau, Elise Chen, Matthew Clarke, Laura Corney, Lachlan Gauke, Caroline Grandjean-Thomsen, Simon Johnson, Richard Kennedy, Clare King, Ava Lam, Michelle Moroney, Alix Nicholson, Jose Ruaya, Ben Ryan, Toby Sinclair, Geoffrey Stewart, and Nick White, who participated in the cultural exchange visit to France

REPORT ON YEAR 10

Tournament of the Minds

To Tommy Chen, Colin Ding, Jacqueline Parker Susan Hoe, and Brian Diep, for their help and assistance.

Debating

To the Year 10 Zone Champions: Andrew Ta, Emily Irvine, Zaine DeSouza, Jacqueline Parker, Elise Chen, Anurag Verma, Sheryl Soo, and Jenni Gray, and to Andrew Ta, for his selection in the Metropolitan East Team of the Junior State Debating Championship, in which they came second.

To Alix Nicholson and Alex Bryant-Smith who represented the school in "Youth Reviews for the Shortlist 2000", an annual event organised by the Childrens' Book Council of Australia.

Sydney Olympics

To Phoebe Haylen who sang in the Olympics Choir and to Caroline Grandjean-Thomsen who was selected to represent the school as an Escort Runner for the Sydney 2000 Torch Relay.

Congratulations also to our tireless charity collectors and to any other student who I may have inadvertently overlooked.

Finally, I would just like to say how much I have enjoyed by last fifteen years at Fort Street, and how much I love and will miss this great school. I have been privileged to teach here and I firmly believe it to be one of the finest schools in Australia. When the time comes for you to leave, please try and avoid what has become a tradition for many students here, and that is to adopt a very laid back and cynical approach to the school and find only negative things to say. Do try and acknowledge the excellent education the school has provided for you and the invaluable contributions of your teachers. In years to come you will always be proud to say that you are a Fortian.

To Year 10 - it's been a privilege and a pleasure to have been your Student Adviser. I hope all of you meet good fortune and happiness along whatever path your future takes you.

Anne Draper
Year 10 Student Adviser.



YEAR 10 - CANBERRA CAMP **17TH - 19TH MAY, 2000**

Our exciting adventure began on an early Wednesday morning, at the car park of Fort Street at 6.15.a.m (it was still dark!) We left for Canberra at 7.00 and passed the 4 hours on the bus by singing sleeping and secretly eating. Finally we arrived at the Parliament House Canberra. There we had an extremely educational and interesting experience of political issues, not to mention the excitement we had in becoming part of parliament for a while. We debated enthusiastically on a bill about the playing of Australian music on local radio. Later we had lunch at Lake Birley Griffin (where we spent every other lunch too). After that it was QUESTACON TIME! Yay!! Questacon was filled with mind boggling puzzles that made you think "ohh that's how it works!". There was even a circus exhibition where the bravest of us tried out the 6 metre free-fall slide!! It was so scary, even Superman would have been frightened.!!

After 2 fun filled hours there, we took the bus to our luxurious 'Motor Inn'. After eating dinner(which we must say was at 4.30 and very generously served..) we made our way to the cinemas to watch Gladiator. It was so hip for us to go and see a movie (at night too) Thanks Mr Millward!

When we returned to the motel, we were all so tired from our bid day out that we fell asleep straight away no being naughty tonight (Naughty, what is naughty??)

Our second day started off at the Art Gallery. We saw zillions of intriguing works, even the fantastic paintings of former Fortian Margaret Preston (how proud we are of her.) After that, we walked over to the High Court. We indulged in what felt like hours and hours (and hours) of talks from know- it -all court people.. Again we were proud to acknowledge the fact that two other Fortians were (and still are) of significance there- Justice Michael Kirby and the Honourable Edmund Barton! We then took a lovely detour through Canberra's exquisite autumn scenery on the way to Old Parliament house. There we went through all the same interesting facts we had been lectured on all of the previous day at the new Parliament House. We ate delicious cuisine for lunch, consisting of cheese, lettuce and ham sandwiches and apples and muesli bars and poppers of imported fruit juices. Yum!

We spent the remainder of our afternoon at the war memorial. We returned to our motel to find our dinner banquet waiting for us - our only food until the next morning. Those cutlets and pieces of lettuce gave us all the energy we needed to go ice-skating that night. Ice skating was the highlight of the camp for everyone....or at least those of us that could skate!

It was so hard for us to get up the next morning and consequently many of us missed breakfast. We got up, showered and packed in 10 minutes. Before we knew it we were packed in the bus, ready for our final destination before reaching Sydney - the place where we learnt the essential skills in voting...

We concluded in our little election that Golf was our grade's most popular sport! After that we had a repeated lunch of the previous days menu - only this time without lettuce! Then we began our long journey home, thinking of how much we couldn't wait to see our parents again!

Elise Chen and Caroline Thomsen 10-0

Canberra attachment

It is hard to imagine that taking 144 year 10 students away for three days could be anything but a painful experience. Not so, as this group of mature, polite and co-operative students proved this to be wrong. The teaching staff received a multitude of compliments from members of the general public as well as from other staff in the facilities we visited. This is really a testament to you, the students on your conduct. From the feedback from students it seems that excursion was high on their most memorable list (maybe Canberra isn't such a boring place after all!). I must say how appreciative I am to the staff who assisted making this a hassle free experience. The gang of six included Di Hubbard, Deb Minutti, Colin Gaskin, Trish Bresnahan and Kay Johnson (a special thanks for organising our supper). It is always difficult to get together as a group of staff members that can get along with the kids as well as themselves and are also prepared to go three days, on call 24 hours a day and with a few hours sleep. Their relaxed but firm attitude really set the tone for the trip and made it such a success

Tony Millward



YR. 9 CAMP

Yr.9 went on a camp to Yarramundi on the second last week of school and had an amazing time climbing, swimming and doing all kinds of activities. Many of these activities seemed orchestrated to test our endurance, for example: high ropes (20m from ground level), low ropes, abseiling, rock climbing, swimming, canoeing.

Many people had a shaky time on the high ropes and the low ropes presented problems of balance. Some people had problems fitting through the tyre.

Despite the size of the swimming pool we enjoyed relaxing and playing water polo, even though the rules were a little distorted. Canoeing was heaps of fun although some people decided to take swimming exercise earlier than the camp instructors planned.

ENVIRO ACTION

Unfortunately Enviro Action has not been as active this year as we would have liked but the paper recycling program has continued.

In the coming year we are planning to expand this program as huge amounts of paper are still going thrown away in the general waste system.

We are also exploring the possibility of introducing a computer cartridge recycling program which will be both environmentally sound and earn some income for the school.

L. Gilbert

At night we presented comedy skits which lived up to their name. It was interesting to see people come out of their shell and work as a team to present sketches of great humour. Trivia pursuit was also popular.

Despite the long lines incurred at meal times, the spooky noises from the possums at night Year 9 all in all had a fabulous time.

We thank the teachers who devoted their time and energy on our behalf.

Christina Lam Yr.9

'In The Swim'

**For a sport, some men made a hymn.
What they called the hymn was a swim.
From early in the morning, 'til late at night,
The love of their swimming kept them bright.**

**Since 1806 swimming's been the game,
and with some swimmers there comes fame.
Winners like Perkins and Michael Klim,
Always cross water they just seem to skim.**

**Slipping across the aqua blue water,
When they win they get a thousand dollars.
On Feb. twenty-two there will be lots of races,
At Ashfield pool, how people will embrace this,
.....swimming!**

By Kelvin Tran 7F

YEAR 7 REPORT

In the Year 2000, a very lively and international group of young people became Fortians. Drawn from Europe and Asia, North and South America, and even from Australia, our present Year 7 quickly revealed a wide range of talent in Drama, Music, and, judging by the excellent paintings hanging in the staff common room, in the Fine Arts.

As Year Adviser, one of my main preoccupations in relation to the students of Year 7 is to encourage cross-cultural exchange. At Fort Street, students have a supreme opportunity to learn about the wide range of people who make up our multicultural nation. Fort Street prides itself on its peaceful, tolerant atmosphere where students of many different backgrounds and traditions can study and relate to each other in friendship and harmony.



YR. 7 CAMP HEAPS OF FUN!

We left at around 9.25 on 16th February, and arrived in time for morning tea. We were then split into cabin groups and went off to have lunch. After that we got our new timetables and worked on some study skills. We had afternoon tea and went swimming in the really nice, but crowded pool.



Canoeing on the dam at the Yr. 7 Camp

To some extent, Year 7 have come to Fort Street to gain knowledge and skills that will enable them to find a satisfying job, but one of my preoccupations is to encourage students to look beyond vocational training. Students come to Fort Street to acquire an education and to search for truth. That is what schools have traditionally been about, and that is what schools should inspire students to do - to search for truth, not scramble for dollars. In the course of their years at Fort Street, our young people should bear in mind that a truly educated person has knowledge of both sciences and humanities. Six years at high school may sound like a life sentence but time passes quickly and before they know it, Year 7 - 2000 will be Year 12 - 2005. At which time I hope I will be able to say that the graduates of 2005 were among the best Fort Street ever had.

Rise to the challenge Year 7.

Serge Yalichev
Year 7 Year Adviser 2000

We had dinner and then had our really nice cool concert, where different people came up and did different acts - some of them were really funny. After that we had supper then went to bed.

On the second day our Peer Support leaders came and we started the day with a peer support session where we used all kinds of different skills. Next we experienced 'camp activities' which were cricket and canoeing (for me). In cricket I got out for a duck, but canoeing was lots of fun. We went around and around this big lake surrounded by reeds and at the end we jumped in the murky water and had a thoroughly mad, icy and reedy swim. That night we made newspaper Cinderellas and had a trivia night. On the way home on Friday we went go carting and it was simply **HEAPS OF FUN.**

The Year 7 camp was held at Merroo Conference Centre at Kurrajong and I for one can thoroughly recommend it

Philippa Janu 7T

SCIENCE

Staff

This year we welcomed Ms Dawkins to the staff, replacing the long serving Fortian, Mr Ambler who was promoted. Ms Nagarajah chose to work three days a week, and Mr Velez completed his first full year at Fort St. During the year, Ms Jamble took maternity leave following the birth of her daughter.

Once again, the staff remain highly involved in school affairs. School excursions, activities and camps across many curriculum areas were staffed with the assistance of the Science teachers, who also contribute to welfare programs in their role as year advisers. Professionally the staff keep up to date with state standards by being involved with the School Certificate and HSC marking in several subjects.

Schools Science Competition.

This competition has been running for more than 20 years and attracts over four thousand students each year. Our best results were obtained by the following students who scored High Distinctions. Chau Tran, Chong Xie, Andrew Dion, Mirza Nurkic, Thuan Ho, John Nguyen, Xian Yuan Chen Davy Lei, Timothy Sam, William Brook, Derek Yeung, Stephen Bernard and Rhys Hearne. In addition to a High Distinction, Two year 9 students, Enoch Lau and Zho Zhang, won medals for scoring the highest marks in NSW.

Science Talent Search.

Our success continues in this state wide competition, with the selection of work by Greg Howe (year 9) to be in permanent exhibition of entries during 2001



Greg's individual research work on Aquaculture also earned him an International Environment Prize to be awarded later in 2001. David Heltsroom (Yr 10) had his working model project tour NSW during 2000 with an exhibition by the Powerhouse. The introduction of Research Projects in the Stage 4 & 5 syllabuses may enable more students to participate in the multitude of competitions and events available as enrichment in Science.

Olympiads

In the latter part of the year, some of our Year 11 students attempted these very advanced exams in Physics and Chemistry. Only 784 Physics students from 251 schools around Australia were eligible to sit for the qualifying Physics exam. Ben Poon took part in some training courses prior to the exam. Both Anh - Tue Le and Ben Poon were rewarded with Credits and should be congratulated on being nominated, and deserve high praise for their effort.



The same two students joined a larger group in the Chemistry exam. Without any training, the group enthusiastically attempted to make sense of the questions, but without success. The message for our keen and talented students is to prepare well in advance for the test. The work is beyond school level, and requires individual preparation, but the rewards are worth it.

Science syllabuses

Some major changes have occurred in high school Science education in NSW. A new Syllabus has been introduced for Science Stages 4 (Yrs. 7 & 8) and Stages 5 (Yrs 9 & 10) which will culminate in a more traditional School Certificate examination. The new Stage 6 syllabuses for the Higher School Certificate courses were also implemented this year. These long awaited syllabus require evaluation and revision of almost every aspect of the Science programs in every school. Our staff has consistently given up their time to attend training programs organised by Universities, professional organisations. Other attended LIG events addressing the new style of assessments for the new HSC. During 2000 Major focus has been on the preliminary courses, leading into the HSC courses examined for the first time in 2001. Different assessment and teaching strategies have been trialed, following new teaching programs, and new texts and teaching resources have been investigated. We soon will purchase data loggers for recording and analysing experimental results by all Science Classes.

Primary Links.

Our staff are keen to support better links with primary schools. Negotiations are under way with Summer Hill PS to enable them to enhance the Science & Technology component of their curriculum. This may involve sharing our facilities and using our students as mentors. The opportunity exists for co-operation in the GLOBE Environment Program, and The Airwatch program (if our funding application is successful).

History report:

I suppose I risk sounding trite by writing "I can't believe my first year at Fort Street is nearly over", but there has been so much change this year that I might make everyone comfortable by being boringly predictable. "I can't believeetc" This year has been full of what I have come to call "Fort Street moments", which have come from teaching the fabulous students at this school; I'm still struck with wonder by the intelligence and insight I have witnessed in so many students I teach or have worked with on other School projects..(Thanks Vedrun and Alex!) And better still so many of you are just as personable, friendly young men and women that it is a pleasure to come to work each day. I hope I never forget what a privilege it is to work here but I guess I'll always shave this little message to remind me that this is the way I think now.

I have also considered myself fortunate to work with such highly professional, committed History staff. While Tom Jackson's outstanding achievement in the HSC - first in the State in 3 Unit Ancient and 2 Unit Modern belonged to him, he was supported by his History teachers. We have all worked hard this year on the new syllabuses to ensure that those opportunities are there for all future History students, and it's worth noting that full marks in the HSC are very possible for students who work with their teacher and follow the advice and directions they give them.

My opening sentence alluded to the many changes we have faced this year, and one of those changes see the end of an era at Fort Street. Michael Browne, a much loved member of the Fort Street staff, by both staff and students alike, has decided to leave us to seek greener pastures, (No pun on Michael's four- legged friends intended here). In the year that I have worked with him I have continued to appreciate his sense of humour and the obvious love he has for the subject. That so many students have expressed regret at his leaving is a measure of the esteem in which he is held. As Michael will not be replaced by a full-time History teacher we will all be located in the History staffroom next to Room 19 from the beginning of next year . So if you want any of us next year, that's where we will be.

**Debbie Miniutti.
H/T History**



History Faculty Members:

**Tony Mulligan, Trish Bresnahan, Lyn Trevini,
Debbie Miniutti, Michael Browne**

FORTIAN SPORT REPORT 2000

Perfect weather, a superb venue, record turnout and the continued supremacy of the Gold House, Preston, combined to create one of the greatest ever moments in Fort Street Sport. On the 10th February 2000, Fort Street held it's first Swimming Carnival of the new century. Once again we were at Ashfield pool but this was where the similarities to past years ended.

Student participation in 2000 has been touted as the largest in years with all grades well represented. However, it was undoubtedly the huge input from Year 12 that made this carnival rise above all others, prompting teachers to label the Year 12 of 2000 as phenomenal.

The atmosphere at Ashfield was transformed for a day into the throbbing heart of Sydney's culture. House allegiance was more passionate than ever with exuberant cheering from the start to the dramatic end. The highlights of the day included several broken records, a huge number of swimmers in the house scramble, and a competitive high tension house relays. The climax and most important event of the day was the watermelon wrestle in which the mighty Gold House won two of the four bouts.

The trend of Gold supremacy was continues throughout the day. There was much anticipation surrounding wither or not Preston would be able to maintain their winning streak of the nineties. Their dominance proved no easy feat as Fortians from all houses and years participated strongly. At the end of the day, however, it was once again the dynamic Preston that won by a massive 189 points, followed by Mawson, Kennedy and Barton.

Congratulations to all Fortians who competed in what eventuated as one of the great Swimming carnivals ever!

Swimming Age Champions

Preston - 548 points
Barton - 456 points
Mawson - 395 points
Kennedy - 348 points

<u>Age</u>	<u>Boys</u>	<u>Girls</u>
12yrs	Adit Gauchan	Philippa Janu
13yrs	Nicholas Tan	Phoebe Finch-Martin
14yrs	Nick Thompson	Beth Goldfinch
15yrs	Greg Waddington	Jessica Brooks
16yrs	Parnell McAdam	Nicole Sutton
17yrs	Robert Lawson	Anna McIlwaine

Broken record

*** 13 years Boys 50m Backstroke Nicholas Tan Old: 42.17 s New:38.78**

The Zone Swimming Carnival

The Zone Swimming Carnival was held in Drummoyne Pool due to the unavailability of the Ryde Centre was under renovations.

There were many outstanding individual performances. In the Age Championships Point Scores we sported the following results:

12 years	13years	15years	16years
Janu Phillipa (3rd)	Nicholas Tan (3rd)	Greg Waddington (2nd)	Parnell McAdam (1st)
Michelle Sutton (5th)	Damian Fox (5th)		Liam Tong (5th)
Adit Gauchan (4th)			



The Zone Swimming Carnival

Our 13 years boys relay team Nicholas Tan, Philip Thai, Leo Boudib and Damian Fox came 1st.
Our 12 years boys relay team Adit Gauchan, Kieran Owens, Brendan Elliot and Benjamin Murphy finished a close second. Well done boys!

Other great results included:

Damian Fox - 3rd in 100m butterfly, 100m freestyle.
Phillipa Janu - 3rd in 50 m freestyle, 100m butterfly.
Michelle Sutton - 3rd in 100m backstroke.
Chriss Jessup - 3rd in 100m backstroke.
Patrick Lunney- 2nd on 100m backstroke
Nicholas White - 1st in 100m backstroke
Gregory Waddington - 3rd in 100m backstroke 2nd in 50m freestyle and 2nd in 100m backstroke
Parnell McAdam - 2nd in 100m butterfly, 1st in 50m backstroke, 1st in 50m breaststroke 1st in 50m butterfly.
Raymon Luu - 2nd in 50m breaststroke.
Nicole Sutton and Caroline Grandjean-Thomsen should be congratulated for their participation in so many events on the day. Thanks girls!

The Zone would like to thank Elaine Chui, Laura Corney, Thomas Costa and Helen James who acted as official timekeepers on the day.

Well done and thankyou to all our competitors. Great to see so many parents- thank you also.

Cross Country Carnival:

Our Cross country carnival was held at Petersham Park Friday 31st March on a clear (Hot!) day. Place getters were:-

	Girls	Boys		Girls	Boys
17's	Beth Degu Monica Tice		14's	Eva Hood Claire Sherrington Zara Fox	Kingsley Drew David Dzeidzic Peter Callender
16's	Caroline G.Thomsen Nicole Sutton Elise Chen	Liam Tong Andrew Birdsall Arun Nadesan	13's	Claire Hill Sarah Kwok Clara Chung	Rory James Sam Xu Damien Fox
15's	Alannah Schumann Jenni Gray Kavita Bedford	Jess McGuirk Nick White Cal McGuirk	12's	Nina Wilkinson Sandy Yao Svetlana Monastyrsky	David Sahota Alex Dacre Allan Chain.

Zone Cross Country Champions:

The Zone Cross country was held on Friday 14th May and after ten years Fort Street Are Zone Champions!
The Carnival was held in and around the grounds of Rozelle Hospital which was a very challenging course. The attendance and performance of our students improved over the past years which resulted in our outstanding win.

Fortian Sport Report.....

Congratulations go to the following students who finished in the top 12 - the first six represent the zone at the Regional Cross Country Carnival.

	<u>Girls</u>		<u>Boys</u>	
12 yrs	Nina Wilkinson	2nd	David Sahota	2nd
	Phillipa Janu	11th	Alexander Dacre	5th
	Sandy Yao	12th		
13 yrs	Claire Hill	11th	Rory James	2nd
	Sarah Kwok	12th	Damien Fox	5th
			Zi Xu	6th
			Richard Christie	10th
			Gregory Lewis	11th
14yrs	Eve Hood	1st	Kingsley Drew	3rd
	Elizabeth Goldfinch	8th		
	Thuy Khuu	9th		
15 years	Allannah Schuman	1st	Jess McGuirk	1st
	Stefanie Wong	8th	Nicholas White	3rd
	Kavita Bedford	10th	Cal McGuirk	5th
16 yrs	Caroline		Andrew Birdsall	3rd
	Grandjean-Thomsen	3rd	Liam Tong	6th
	Laura Corney	8th	Simon Johnson	7th
	Sheryl Soo	11th	Igor Butorac	9th
17yrs	Monica Tice	3rd	Damjan Vlastelica	8th
	Kate Goudie	8th	Michael Tromans	9th
	Joanna Lin	10th	Martin Kurek	10th
			Rhys Hearne	11th

Well done to those students and all who participated. The Regional Cross Country was held on Wednesday the 14th June.

Fortian Sport – Athletics 2000

This years Athletics Carnival was held at a new venue, E.S. Marks Field instead of the usual warm up track at Homebush. Despite not being out at the Olympic site, the Kensington venue certainly was a more than adequate replacement.

It was beautiful sunny day, when a record number of Sportians piled onto buses going to the venue. They arrived there at around 9 am after an hour long, cramped and uncomfortable ride through the morning traffic of Sydney.

The atmosphere was uplifting as hundreds of Reds, Yellows, Greens and Blues poured through the gates ready to compete.

The opening 1500m race got the ball rolling with many great runs. By the time the 100m races got under way the entire crowd was fired up and cheering for their house.

However, despite the great day, there was one let down. A new House, Hetherington, named after the creator of Mr Squiggle(Fortian Norman Hetherington), invaded many races, creating chaos and confusion around the stadium. Some of them were still finishing their 1500m when the relays began. This disturbance was ignores and the true sporting spirit carried on.

The points were so close, however on the day there was really only one winner.

The Year 2000 Fort Street Carnival was an overwhelming success with many records broken and a great time had by all. Hopefully we will this again next year (minus Hetherington).





ATHLETICS 2000

Final results and Age Champions to follow
Jess McGuirk and Peter Callender.

Age Champions

Boys

12	Alexander Dacre
13	Rory James
14	Christopher Jessup
15	Wister Wu
16	Liam Tong
17	Steven Turner

Girls

Nina Wilkinson
Sophia Kaplan
Claire Cherrington
Allanah Schumann
Ella Pong
Jocelyn Kang

Final Point Scores:

PRESTON	1ST	519
BARTON	2ND	495
KENNEDY	3RD	414
MAWSON	4TH	347

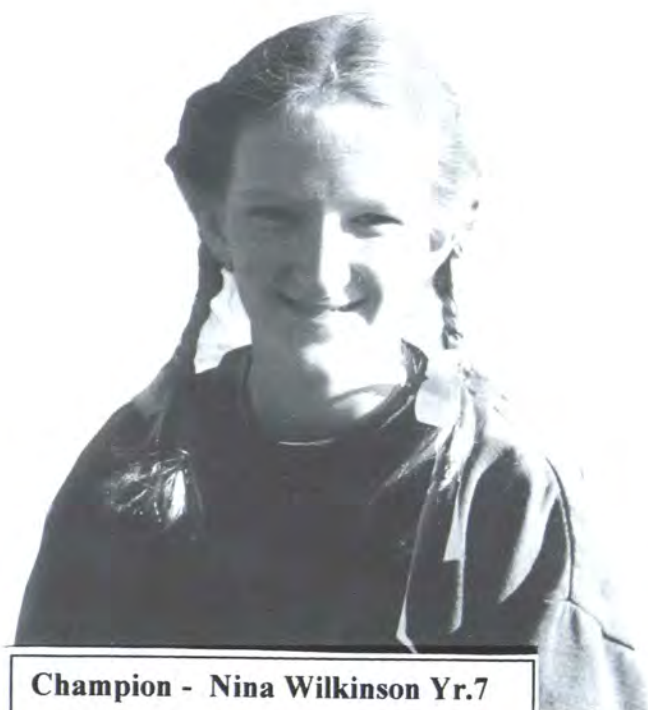

Champion - Nina Wilkinson Yr.7

Records Broken:

1.	Alexander Dacre	12yrs boys shotput	Old:9.10m	New:9.59
2.	David Sahota	12yrs boys high jump	Old:1.32m	New:1.4m
3.	Allanah Schumann	15yrs girls 400m	Old:1.09.03	New: 1.05.35
4.	Wister Wu	15yrs boys 200m	Old:25.70	New:24.82
5.	Igor Butorac	16yrs boys high jump	Old:1.73	New:1.83

Zone Athletics Carnival

The Carnival was held at ES Marks Field on the 21st and 22nd June as Homebush was unavailable due to Olympic preparations. Nevertheless, the venue proved to be a very adequate back up. we actually broke tradition and lined two day magnificently sunny days.

Well done Sportians.... a very close runner up behind Malvena High School. Once again we hosted the carnival and, thanks to many of our students who help in official roles, the two days ran smoothly. There were a number of outstanding individual performances with the following results in the race for Age Championship:

	<u>Girls</u>		<u>Boys</u>	
12yrs	Nina Wilkinson	2nd	David Sahota	1st
			Alex Dacre	2nd
14yrs	Eve Hood	3rd	Chris Jessup	5th
15yrs			Wister Wu	1st
			Cal McGuirk	4th
			Jess McGuirk	6th
16yrs	-		Igor Butorac	3rd
			Liam Tong	5th
17yrs	Keely McNamara	6th	Martin Kurek	3rd



ZONE REGIONAL ATHLETICS CARNIVAL

The following came first or second in an event to represent the Zone at the regional Athletics Carnival:

<u>Name</u>	<u>Event</u>	<u>Place</u>	<u>Name</u>	<u>Event</u>	<u>Place</u>
Nina Wilkinson	200m	Reserve	Igor Butorac	100m	2nd
	100m	Reserve		High Jump	1st
	80m Hurdles	1st		200m	2nd
Claire Hill	Long Jump	2nd	Caroline		
Rory James	Shot Put	Reserve	Grandjean-Thomsen	3000m	1st
	Discus	2nd	Bob Jiang	Shot Put	Reserve
Tatzun Korecki	Javelin	2nd		Discus	1st
	Shot Put	2nd	Ava Lam	Triple Jump	Reserve
David Sahota	800m	Reserve	Grant O'Donnell	Javelin	2nd
	80m Hurdles	1st	Nicholas White	800m	1st
	Long Jump	1st	Kate Goudie	Long Jump	2nd
	High Jump	1st		Triple Jump	2nd
Thomas Elliot	90m Hurdles	2nd		200m	2nd
Kristina Erzikoz	Javelin	2nd		100m	2nd
Eve Hood	800m	1st	Liam Tong	200m	Reserve
	300m	Reserve		400m	1st
	1500m	1st		800m	Reserve
Christopher Jessup	800m	2nd	Cassian Cox	Shot Put	2nd
	Discus	2nd	Martin Kurek	400m	2nd
Bowani Raffan	100m	2nd		100m	Reserve
Claire Cherrington	Long Jump	Reserve		200m	Reserve
	High Jump	1st	Keely McNamara	17x3000m	Reserve
Allannah Schumann	800m	1st		Open 15000Walk	2nd
Wendy Wu	Long Jump	1st			
	100m	2nd			
	200m	1st			
	Shot Put	2nd			
	100m Hurdles	2nd			
Andrew Birdsall	1500m	Reserve			
	3000m	2nd			

Igor Butorac making his high jump record in style.



FORTIAN SPORT 2000

Best and Fairest

Grade Sport

Open basketball
15's basketball
Open softball
open touch
15's touch

Grade Sport

Open cricket
15's cricket
ope netball
open volleyball
15's volleyball
Open touch
15's touch

Girls

Natalie Goh
Michelle Moroney
Jacqueline Parker/ Tracey Ying
Caroline Grandjean-Thomsen
Laura Corney

Boys

Arun Nadesan
Sameer Chowdhury
Igor Butorac
Sadunshu Bhardwaj
Boyu Zhao
Michael Moroney
Kevin Tran

Grade Team Success

Fort Street had one of our most successful Winter Grade Competitions this year, with seven teams- the Girls' Open and 15's Volleyball, the Boys' 15's AFL team , the Open Basketball and Rugby teams and the 15s soccer team- reaching the finals.

After a slow start to the season and many lunchtime training sessions, our Girls' Open and 15s Volleyball teams became Zone Champions. Congratulations to all our team members. Both teams were placed in fourth position at the Senior Finals.



The Open Girls Volleyball team: included Jessica Au, Carmen Chan, Alice Chen, Many Hunynh, Louisa Li, Haiye Ngyun, Alice Qian, Eilen Saekang, Monica Tice, Sarah White, Tracey Ying, Weina Zhu, Susan Ho, Jennifer Ann, Amy Bao, Roby Chiu, Lucy Geremin, Ara Ko, Anna Lucewicz, Haily Nguyen, Belinda Tran, Judy Tu, Vina Xiao, Jessica Zhang and Melissa Ellingworth were in the 15 Girls Volleyball. A special thank you to the boys who helped coach the teams- Tim Sam, Edward Byun, Angus Tiet, Boyn Zhao.

FORTIAN SPORT

Summer Grade Sport Competition.

Thanks to the effort of the Sportian team members, our coaches, including some student coaches, we had a very successful summer sport competition. The following teams competed their way to the Grand Finals: 15's Girls basketball, Boys open cricket.

Congratulations and thank you to **Alfred Shui** and **Victor Frankowski** who coached the girls (both Open and 15's) basketball teams. The 15's made it to the final after a not-so-confident start. The girls appreciated your time and effort.



15's Girls Basketball Team:-

Back row: Zaineb De Souza, Cheryl Soo, Alfred Shui (coach) Ava Lam, Catherine Santangelo.

Front row: Ellem Lee, Alix Nicholson, Marianne Moroney, Elaine Kwan, Janelle Espinas



Open Boys Cricket Super 8's

Back row: David Collits, Clancy Yeates, Alex Stewart, Andrew Birdsall, Julian Boyce, Dip Hor.

Front row: Arun Nadesan, Prasanth Ramkumar, Gaurav Bhardwaj, Anurag Verma, Araf Zafer, Jaye Kathavate

FORTIAN SPORT
Best and Fairest winter Grade Competition.

Girls

Open Volleyball
 15's Volleyball
 Open Soccer
 15's Soccer
 Open Netball
 15's 'A' Netball
 Open Hockey

Boys

Haiyen Nguyen
 Susan Hoe
 Ella Pong
 Claire Cherrington
 Amelia Roberts
 Shruti Kalhalli
 Laidee Wong

Girls

Open Soccer
 15's Soccer
 Open Hockey
 Open Rugby
 15's A.F.L.
 Open Basketball
 15's Basketball

Boys

Jeremy Sung
 David Campbell
 Cassian Cox
 Steven Turner
 Kevin Tran
 Andrew Diong
 Zane Ma

HALL OF FAME: OUR SPORTIANS

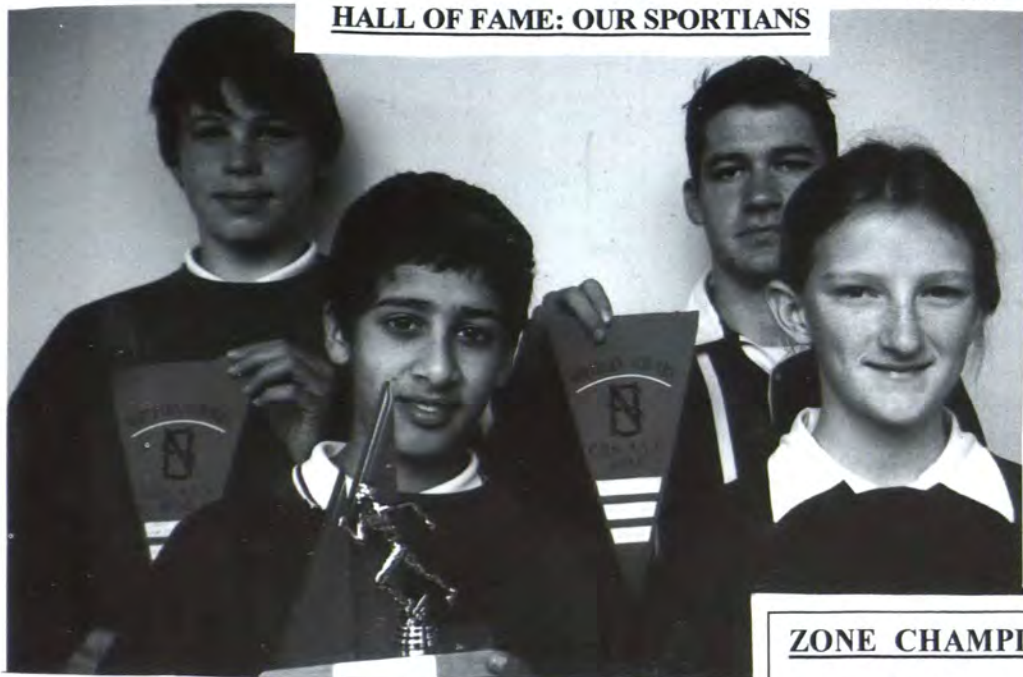

ZONE CHAMPIONS

Back Row: Alex Dacre 2nd - Yrs 12 Boys, Martin Kurek 3rd - Yrs.17 Boys
 Front Row: David Sahota 1st-Yrs.12 Boys, Nina Wilkinson 2nd - Yrs.12 Girls

**WE WERE REPRESENTED
 AT THE OLYMPICS.
 OI! OI! OI!**

The Olympic Torch had been around the world and finally it came to Sydney. Two of the lucky 'chosen ones' were Fortians. These lucky but deserved Fortians were:-

- *Caroline Grandjean-Thomsen
- *Liam Tong

These students had the honour of running as escorts alongside the torch Bearers. Most schools had only one runner chosen by SOCOG. We had two. Congratulations Caroline and Liam.



Keely McNamara
 National Rowing

Claire Cherrington
 State Soccer



Anna McIlwaine Yr.12

An outstanding Fortian - Anna continues to balance her extraordinary sporting achievements with her senior academic studies.

Anna returned from Canada on the 26th January having successfully competed at The World Junior Diving competition where she was placed and admirable Second. Congratulations Anna!

Tournament of Minds

Social Science

The Team

Jacqueline Parker	Year 10	Akash Yao	Year 8
Tommy Chen	Year 10	Luci Hartley	Year 7
Colin Ding	Year 10	Alannah Walsh	Year 7
Xavier Mckenzie (Facilitator)	Year 11	Rory James	Year 7

The social science team won at regional competition (it was tough!!!) and progressed to the state final on a Sunday in September normally reserved for Father's Day. They had a couple of hours to write and rehearse a play on the following theme: "A group of people go on a journey together and along the way they must overcome personal difficulties to resolve a crisis."

Scene 1: The Gods lose their powers.

Narrator: The Gods of Olympia have reigned over Helene for thousands of years. It seems that their reign shall never end.

[enter gods]

Zeus: You, Hera, Mars, Aphrodite, it is time again to tour our realm. This time we will go to Anatolia.

Hera: Anatolia? That's in Asia Minor isn't it?

Mars: Yes! You've done your homework. They haven't had a war for one hundred years. Alright! *[rubs hands]*

Aphrodite: A war born out of lust and jealousy.

Narrator: Zeus, Hera, Mars, and Aphrodite alighted from Olympia and began their tour of Anatolia.

[Gods walk across stage]

[Enter 2 peasants playing Gameboy]

Hera: See how the worthless worms are mesmerised by Barbarian magic!

Mars: Hah! Stupid Mongrels!

[Hera points her hand]

[Peasants start arguing]

Hera: Hahahahaha! *[evil laughter]*

[Gods walk on.]

[A peasant drives a cart very close to the gods]

Zeus: Ah! Insolent peasant! Flick water on my toga why don't you!

[Zeus throws lightning bolt]

[SFX Explosion]

Zeus: That should teach them.

[Peasants visibly crushed by the power of Zeus]

Narrator: Everywhere they went jealous Hera, remorseless Zeus, war-like Mars and lustful Aphrodite left a trail of destruction. Through Aphrodite's efforts, Troy and Greece fought a long and hard war over Helen. Mars in his thirst for violence killed millions in the war.

Zeus: Aha! Here we are, Spagetos in South Turkey.

Evangelist: Praise the Lord!

TORNAMENT OF MINDS

Zeus: Ah! Insolent peasant! Flick water on my toga why don't you!

{Zeus throws lightning bolt}

{SFX Explosion}

Zeus: That should teach them.

[Peasants visibly crushed by the power of Zeus]

Narrator: Everywhere they went jealous Hera, remorseless Zeus, war-like Mars and lustful Aphrodite left trail of destruction. Through Aphrodite's efforts, Troy and Greece fought a long and hard war over Helen. Mars in his thirst for violence killed millions in the war .

Zeus: Aha! Here we are, Spagetos in South Turkey.

Evangelist: Praise the Lord!

levangelist makes a sign of the cross

Zeus: I shall strike him down with lightning!

Hera: Nothing...

Evangelist: I had a dream... and I woke up. It was a good dream too!

Mars: I shall decapitate him with the Sword ofHephaestos!

{Mars swings sword to no effect.}

{Cart driver drives through}

Driver: Hey you! Get out of my way you peasants!

[freeze all]

{enter Plato}

Plato: Hi, I'm Plato of Athens; you may remember me from such works as Monologue and Dialogue.

Here is an interesting phenomenon first discovered by Hero of Alexandria. When people stop believing in gods, they lose their powers. Strange but true.

{Gods unfreeze,}ump out of the way of the cart.}

Zeus: You just wait til I get my power back! You shall be burned for eternity in Sulphurous Hell!

Hera: Oh *me!* Why is this happening to us?

Mars: Watch this. *[punches a peasant]* Believe in me! Believe in Olympia Peasant: No! What have the gods of Olympia ever brought us but hunger and war?

Zeus: Well, that didn't work.

Mars: Oh! What a predicament!

Hera: It's all your fault, etc.

Zeus: Hah! Look who's talking...

{General argument & melee }

Hera: Oh look! A catalogue! *{Picks up somethingfrom the group}*

Zeus: *{reads}* K-mart Father's Day Specials...

Aphrodite: Look how happy these families are...

Hera: You know what?

Mars: What?

Hera: I think I know the answer. Our followers see us as parents. Zeus, are you not Father of Gods and Men?

We should love them like family. The back~ them-out-of-mud-and-strike-them-with lightning method just doesn't work any more. See this? The message is, love and you shall be loved. See how the departments in the catalogue are equal? That is how a well managed Pantheon functions.

Mars: I see your point. We should love our believers. That is the only way we will regain our powers

Scene 2 - The Gods realised where they were wrong.

{Enter Peasants }

Peasant 1: Oh no! My husband/wife is under those rocks

Peasant 2: Oh help us Gods!

{Enter Zeus and Mars, disguised, and heave rocks away.}

TORNAMENT OF MINDS

Peasant 1: Oh great Olympia! Thank you for sending us these good men.

[Exeunt all]

[Enter Peasant couple in heated argument]

Peasant 3: You and your gambling are wasting our money away!

Peasant 4: What about you? You spend all your time gossiping by the well! You don't even feed the dog any more!

[Enter Hera and Aphrodite, disguised]

Hera: Calm down, child. The road of marriage is not always even, you must walk it together .

Aphrodite: Only when the family co-operates will there be prosperity.

Peasant 3: Thank you. We really needed the counselling.

Peasant 4: Thank the gods for you.

Scene 3 The Gods are restored to their former powers.

Zeus: Oh look, my powers are back!

Hera: So how did you work to get your powers back?

Zeus: I used my experiences as a weather god to forecast weather for the peasants, bringing them good harvests and risk minimisation.

Mars: I used my strength to help the people with manual labour.

Hera: I worked as a marriage counsellor, to reduce domestic violence and divorce rates.

Aphrodite: I used my experiences and worked as a matchmaker, bringing lovers together .

Hera: May this be a lesson to us all. Our believers are our children.

We must treat them with love, not contempt.

Notes:

1. Anatolia: The Asian part of Turkey;
2. Zeus (Jupiter): The chief and sky-god in Greek mythology. Has a reputation for infidelity.
3. Hera (Juno): Wife of Zeus and goddess of marriage. Has a reputation for revenge.
4. Aphrodite (Venus): Daughter of Zeus, goddess of sex and love.
5. Mars (Ares): Son of Zeus, god of war.
6. Troy: Ancient city in Anatolia, site of legendary Trojan War.
7. Helen: Woman of legendary beauty, the object of the Trojan War.
8. This piece was inspired in part by Terry Pratchett's *Small Gods* and *Xena: Warrior Princess*.



TORNAMENT OF MINDS

MATHS/ ENGINEERING

THE TEAM

Brian Diep	Year	10	Vita Gray	Year	9
Susan Ho	Year	10	Elwin Cross	Year	7
Simon Sheik	Year	9	Paul Dutkowski	Year	7
Arwen Cross	Year	11	Rommel Ceguerra	Year	7

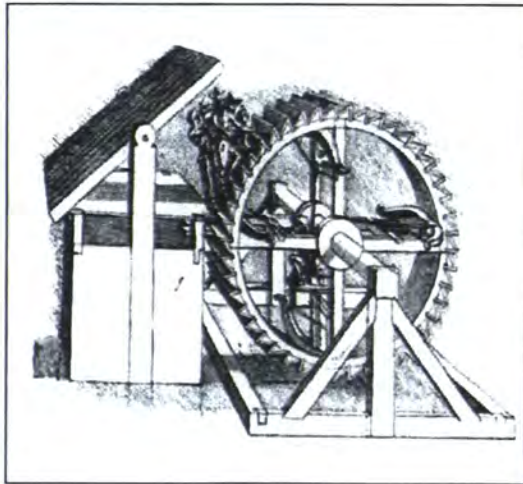

For the regional competition Maths/English had three weeks to build a machine out of pieces of junk. The machine had to complete three revolutions in exactly thirty seconds after a string tie was cut....and carry a logo about the turn of the millenium. They had to write a play and make costumes. The play had to last exactly ten minutes. It was a very tight schedule but they completed the task brilliantly. Maths/English won at Regional. Hurray!

For the state competition Maths/English were given a couple of hours and a box of junk to make a launching device for a small paper plane. They had three attempts at landing the plane at a target which was four metres away. Rommel saved the day with his brilliant dead-eye accurate shooting. The whole team worked well to write and produce a good play.

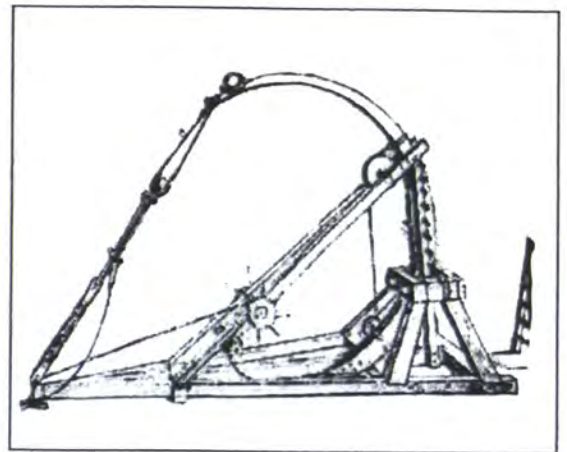

INSTRUMENTAL MUSIC PROGRAM



The IMP this year was, once again, a true success. The ensembles were bigger, louder and more in tune than ever before. We once again, dazzled the crowds at our mid year concert with our "Dance Fever" theme. The vibes were electric that night with it almost being impossible to keep the crowds from dancing. Highlights of the evening included a rendition of "Chatanooga Choo Choo" performed by Emily Irvine, Nina Pollock and Elise Chen of Year 10, accompanied by the Junior Stage Band. The other most notable highlight was the Senior Stage Bands bonza performance of "Jailhouse Rock" and boy were we surprised when The King " himself walked in that door.

The performances didn't stop there. All year we have been really busy rehearsing, auditioning and performing in the independent competitions and concerts. Towards the beginning of the year the senior ensembles auditioned to take part in a variety of concerts and festivals, including the Sydney South East Metropolitan School Festival. Both the Senior Concert and Stage Bands were successful, and the Senior Strings also performed at the Yamaha Musical Festival and went away with second place.

The Junior Stage and Concert Band as well as the Senior String Ensemble made appearances at the Grosvenor Centre. These were rewarding concerts to perform and many thanks were given to us in return. The tour this year was even more amazing than last year. Who could think that Armidale could be in anyway entertaining, but once we rocked up with all our gear, the place came alive. We played for gorgeous little kids in little towns where our ensembles were bigger in number than the entire school body including Kentucky Primary and Black Mountain Primary. Who could forget Chela winning hearts when

she sang 'Fever' with the Stage Band.

I.M.P. Camp was also fun this year with much excitement and hyjinx plus a warming concert for the parents. All the hard work and effort paid off and it was a great success.

One particular performance that is sure to put Fort St and the IMP on the map, was the Minister's Awards for Excellence at the Powerhouse Museum. Every year a school ensemble is asked to perform at these awards, and so, we were extremely honoured when not only the senior Concert, but also the Senior Stage Band was asked to play. Besides the fact that the Minister was not present at the ceremony, it was a big hit, with not only the visitors the Powerhouse dancing away, but many of the high profile people from the Department of Education and Training as well.

But by far, the most successful and amazing concert of the year had to be our end of year performance titled "A Classic Finish", with all the bands performing to demonstrate the hard work and effort put forward by all the students, tutors and band leaders. None of this could have happened without the enthusiasm and commitment from Phil and John, the IMP Executive, all the parents who donated their time to IMP, the tutors who help us master the pieces, all the students and the everlasting support of the school. Our heartfelt thanks.

Report written in collaboration, by: Nick Findlay, Emily Irvine, Patrick White



2000 has been another memorable year in the life of Visual Arts, a challenging year with complex changes taking place in the theory and practice of art.

Much time, effort and thought by the Visual art staff have gone into successfully developing strategies to produce innovative programs that address these changes. We believe that whether Art is used to provoke reactions, express viewpoints, challenge opinions, commemorate beliefs, solve problems, or develop awareness, the practice of making and responding to art involves a variety of thinking processes.

As an area of study, art is a means for our students to develop their own imaginative intelligence.

The quality of Visual art students continue to improve and the increased interest in our courses means that results are excellent. The outstanding achievements were:

- ◆ This year our school participated in the Operation Art 2000 project which is a joint initiative of the New South Wales Department of Education and Training and the New Children's Hospital, Westmead. Operation Art is a program which encourages young people to create artworks for children in hospital.

Lilian Lau and **Jennifer Ahn** of Year 9 submitted two beautiful still life pastel drawings. Lilian's drawing was selected among 450 entrants from across the state to become part of the permanent collection of the New Children's Hospital, Westmead. Lilian's artwork was exhibited at the Art Gallery of NSW from 24th October to 5th November 2000. Jennifer's drawing has been selected for Nagoya's 22nd Sister and Friendship City Children's Art and Calligraphy Exhibition in Japan.

Professor John Yu, who was responsible for the development of the hospital a Fortian, reflects:

"Art is an important part of the healing environment that is the hospital. It is a tangible expression of our philosophy of caring."

◆ **Mowena Wilkins** Year 12 has had her 2 Unit HSC artworks "Blackwattle Bay" series selected for Artexpress. Mowena was interviewed for the television promotion of Artexpress. The school has purchased one of these outstanding drawings for the foyer, the first purchase in the senior students art acquisition program.

◆ **HSC 2 Unit** results were outstanding with 11 out of 25 students achieving in the 90-100% percentile band. Congratulations to these students! Thanks to the Visual Art Staff who during 2000 gave consistently of their time and energy for the benefit of our students. Ms Thornhill, Ms Page and Ms Buckland gave support and encouragement to their students and organized a wide range of enrichment activities for all years. Selected students work was proudly displayed on a changing basis throughout the school. The Visual Art Staff would like to thank all the students who participated in these activities and we look forward to another rewarding year.

**Vivienne Dadour – Head Teacher
Visual Arts**



Vesna Trobec Yr.9



William Nguyen Yr.10

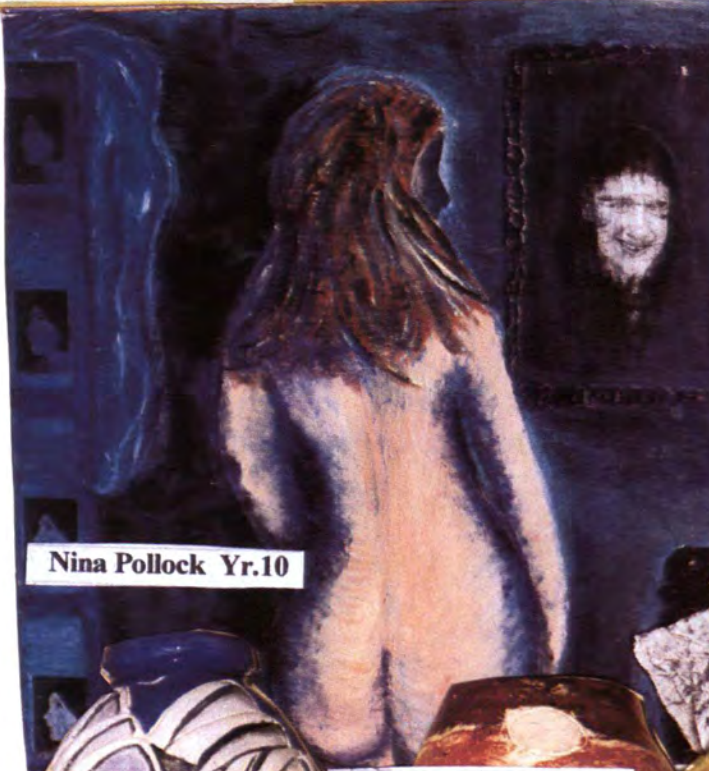

Nina Pollock Yr.10

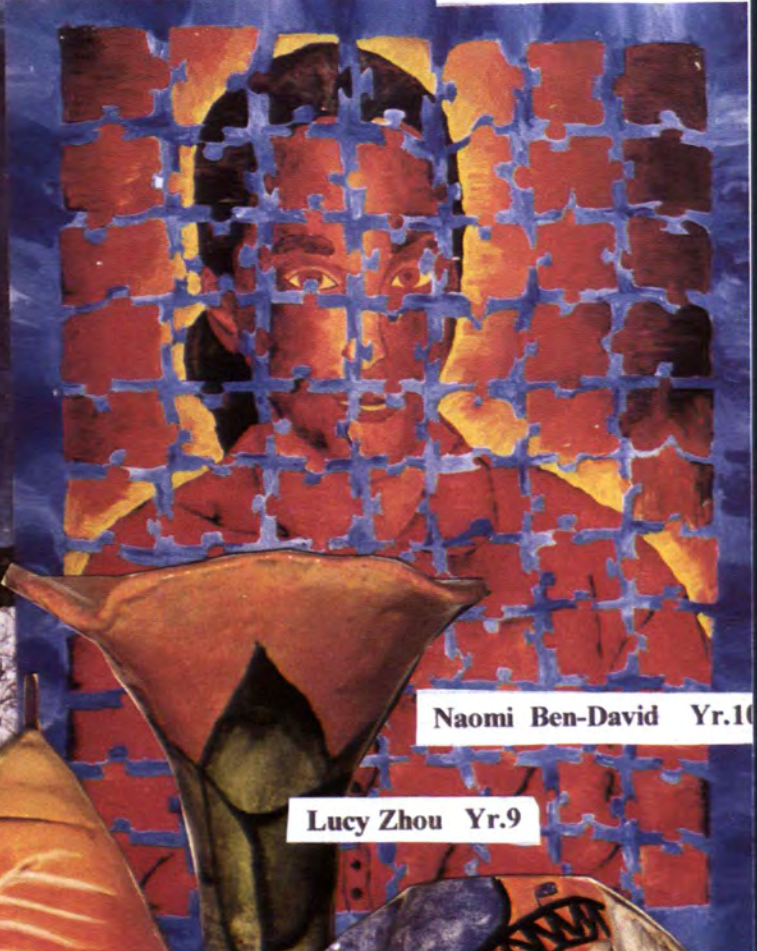

Naomi Ben-David Yr.10

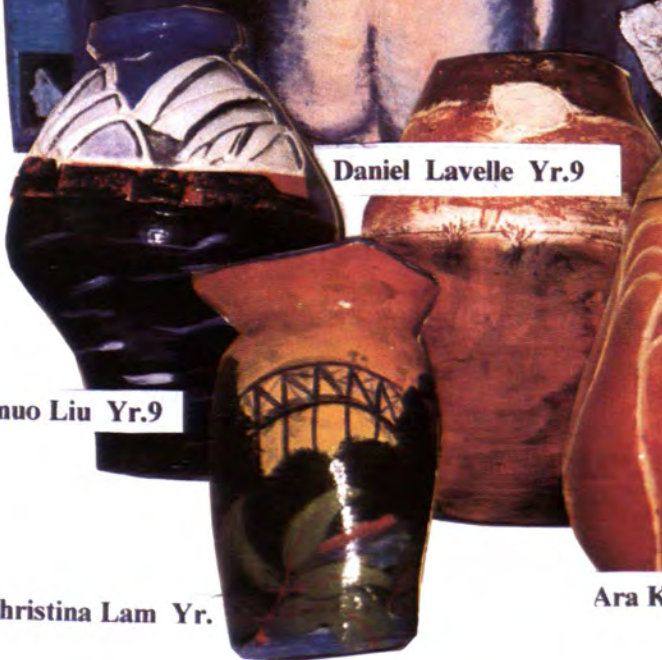

Daniel Lavelle Yr.9



Lucy Zhou Yr.9

Shinuo Liu Yr.9

Christina Lam Yr.

Ara Ko Yr.9

Chiara Bianchino Yr.9

HSC VISUAL ARTS

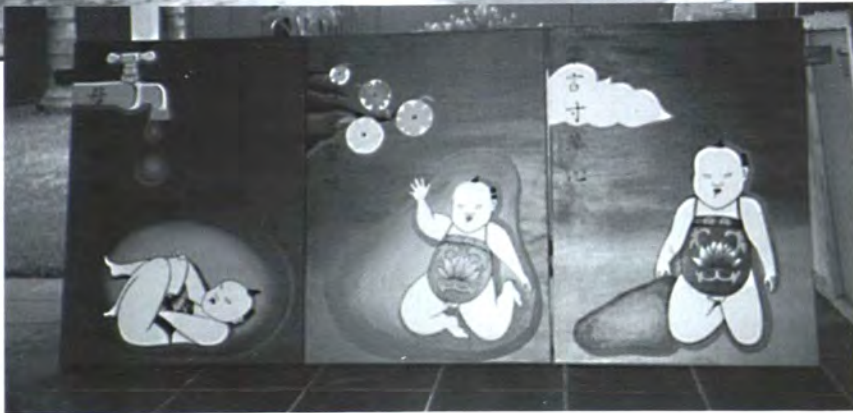

'RIFFING ON ROMEO & JULIET

Year 7 & 8 Drama 2000

Throughout Terms 3 and 4, Year 7 and 8 Junior Drama Ensemble has been hard at work creating their own modern version of Shakespeare's "Romeo and Juliet".

Working with Glenda Linscott, a Graduate of NIDA (National Institute of Dramatic Art) they translated selected pieces of Romeo and Juliet into modern language and even wrote their own versions of scenes and poems relating to certain themes of the play.

The Ensemble, consisting of:

Nick Bryant-Smith	Lacri Nacu
Walter Chavez	Emma Neurath
Bridie Drummond	Keiran Owens
Laura Fairbourn	William Wallace
Beth Goldfinch	Liam Whiting
Claire Hill	Amber Wilcox
Nick Lupi	Nina Wilkinson
Robert Ma	
Fergus Montgomery	

These students performed their finished project "Riffing on Romeo and Juliet", in the School Hall on Thursday 30th November, 2000. The play was a hit and was enthusiastically received by all who attended (according to the positive feedback of many), with cameo performances from the Junior Concert and Stage Bands adding a little more spice to the show.

This performance marked the beginning of the Drama Faculty's initiative to foster an expanded Drama programme for interested students both junior and senior levels.

Many thanks go to Glenda Linscott for her inspiration, and Jon Suffolk for his amazing stage management. Without their tireless efforts, the show would not have gone on. Congratulations also go to all the Junior Drama actors. Not only was "Riffing on Romeo and Juliet" a tremendous success, it was great fun to work on and perform.

Amber Wilcox – 8R



Lauren Tarr, Tom Keenan-Brown and Jessica Clatworthy performing at Open Night 2000



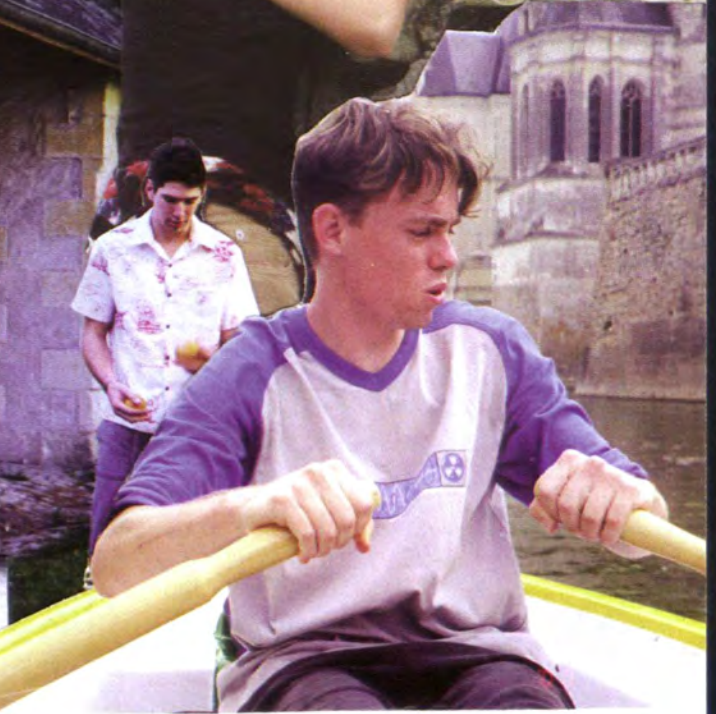
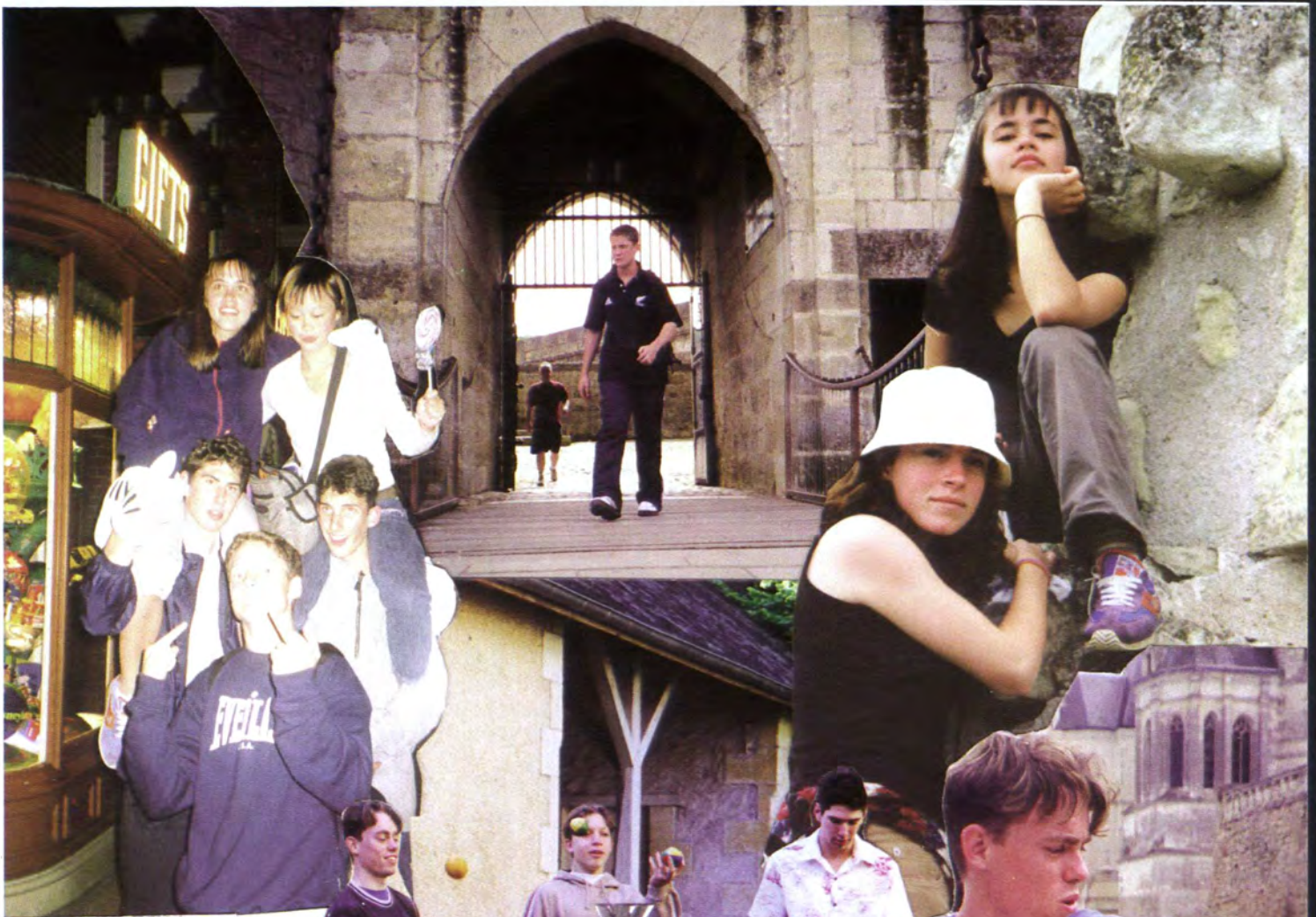

FORT STREET IN FRANCE



DRAMA REPORT – 2000

Light, characters, action. That is how the dramatic year at Fort Street has unfolded since February. Students have been involved in a variety of drama performances, workshops and activities.

2000 has seen an exciting development in classroom drama at Fort Street. For the first time students in Year 7 have all been exposed to drama on a regular basis. Year 7 classes have all had one period per cycle in which they have experienced a wide variety of drama activities. The program has allowed Year 7 students to develop their group work, vocal, communication and movement skills. The culmination of this program saw 7R devise a play under the direction of Ms Joanne Martin, to welcome the students of Year 7 2001. Next year in Year 7 and 8 will experience drama twice per cycle.

February saw Fortians from the Class of 1999 perform at the "Onstage 1999" HSC Drama Showcase at the Seymour Centre. The showcase program is made up of exemplary works from the HSC. Nicholas Curnow, James Lane, Benjamin David and Lauren Frazer had their group devised piece "The Ties That Bind" selected and they performed their work to students and parents from throughout NSW. They are to be congratulated on their success. Chris Parris (Class of 2000) has had his solo performance nominated for the "ONSTAGE 2000" program. Congratulations Chris.

Drama Groups from year 9, 10, 11 and 12 performed original group devised works at the annual Performing Arts Night. The Year 11 item, "The Real Olympics" was then selected to be performed at the State Drama Festival at Parramatta Riverside Theatre. The group-devised work was a tongue-in-cheek look at corruption and its effects on the Sydney Olympic Games.

The senior drama students also embarked on an ambitious project for the annual Senior Drama production. Under the direction of Mr Jon Suffolk and Ms Andrea Connell, the students performed extracts from "The Doll Trilogy" by Ray Lawler.

Although many students were involved, it is important to recognise the performances of Julia Britton and James Wright. Julia and James played the demanding roles of Olive and Roo respectively. Their commitment to the project and excellent performances are to be commended given the difficult nature of the roles and the timing of the performances. Ms Connell and Mr Suffolk would like to congratulate all the students involved for their superb efforts.

HSC Drama students also presented excellent performance, design, script writing and theatre critique projects as part of their course. As previously mentioned, Chris Paris has achieved excellent success with his solo performance and the other members of the class worked tirelessly on their Group and Individual Projects. Nicholas Dixon-Wilmhurst will continue his drama studies in 2001 at the prestigious Western Australian Academy of Performing Arts. We wish all these students every success in the future.

Many students are involved in putting together performance events at Fort Street throughout the year. It is often the technical and backstage crews who receive the least recognition and it is to these students that the school offers congratulations and thanks for their hard work. Of particular mention are Jose Ruaya, Patrick Lunney, Alex Bryant-Smith, Ben Ryan, Hagen McCraig, and Tom Radford of Year 10. These students and the teams of students from Year 10 who have operated the technical aspects of Performing Arts Nights, Senior Productions, HSC Drama performances, and IMP Concerts are to be congratulated on their excellent contribution to the Performing Arts and the school.

Jon Suffolk
Performing Arts

Max Schollar-Root & Claire Cherrington
'Thespians in the making'



CAREERS REPORT

This past Olympic and Paralympic year has seen many opportunities for students. Fifty eight year ten students attended a four hour Customer Service TAFE Course. This course was funded by the Government, trained students and adults alike in how to deal with people effectively from a customer service point of view. It focused on people from overseas destinations and those with disabilities.

A number of students took up Olympic opportunities to work in hospitality or cleaning at pay rates that were truly amazing. Numerous companies contacted the school with part time job opportunities. There were two companies who contacted the school looking for 1,000 part time workers in hospitality while another searched for 1,000 workers in cleaning and gardening.

I have written a separate article concerning the Class of 1999 tertiary destinations and scholarships. Numerous lunchtime talks by tertiary representatives proceeded while numerous newsletters tried to keep Year 12 up to date in the tertiary and employment scenes.

Internet sites have become even more informative and user in accessing tertiary information. Year 12 students were required to attend a lunchtime talk on applying for University and were supplied with a newsletter and University Admission Centre Guide.

The opening of the Paralympic Games heralded the start of the HSC exams. Last year HSC subjects results and UAI's were available before Christmas.

The Young Achievements Skills Program and the Work Experience Program proceeded well while Vocational Educational has seen Peter James as the last student to complete a one unit JSSTAFE under the old HSC system.



Peter James - Year 12

The current Years 10 and 11 students face the SC and the new HSC with two units of English mandatory in their UAI. The new HSC has created many enquiries from parents while the scaling of HSC subjects continues to mystify many people.

The Board of Studies (BOS) duties with the provision of the Internet to enter and change students entries has been of crucial importance in the flexibility offered to coordinate entries in years 10 - 12. Additional BOS duties such as the special exam provision for students doing the HSC and SC along with illness/misadventure applications, checking entries and so on seems like never ending cycle. A cycle that sees many Fortians succeed.

Phil Canty, Careers Adviser

Six year ten students attended the Inaugural Student Shadow Scheme on 2-4 August at Sydney University. The students gained an increases awareness of science, architecture and engineering course and career options and experienced a taste on campus life.

Pictured from the front, left to right are:-
Zaineb De Souza, Alisha Wong, Grace Chan, David Helstroom, Edwin Ma and Samseer Chowdhurry.

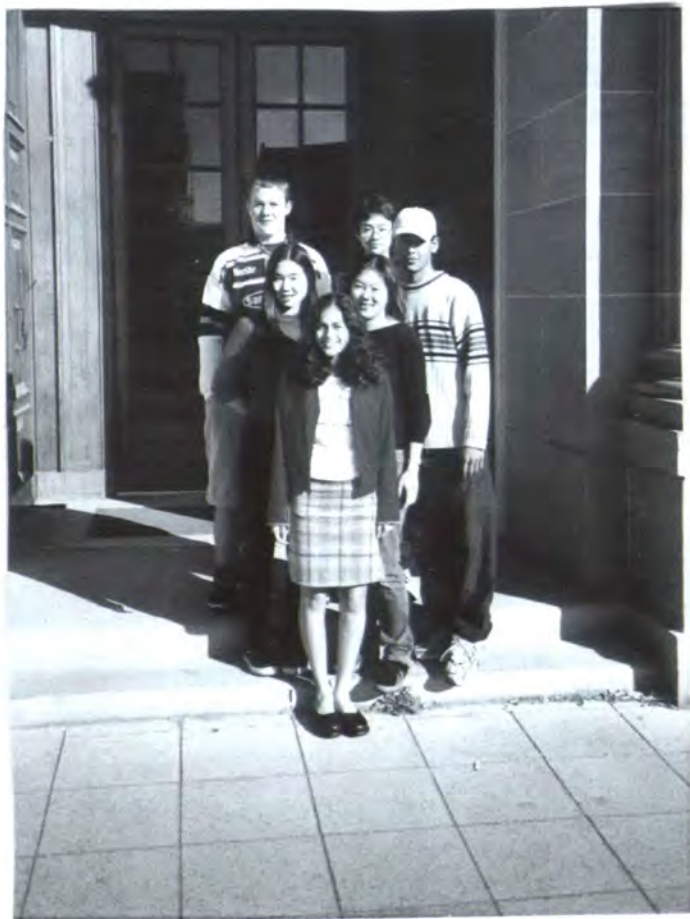

TAS DEPARTMENT

DESIGN TECHNOLOGY

FOOD



TEXTILES

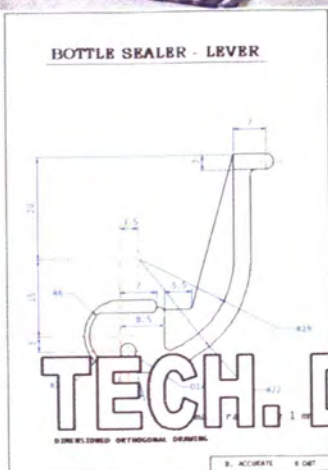

TECH. DRAWING



Electronics

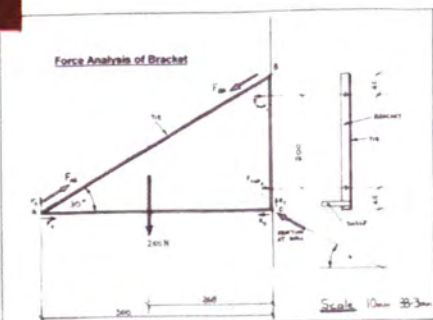

ENGINEERING

$\sigma_{AB} = 7.44 \text{ MPa}$
 $\sigma_{BC} = \frac{15}{25} \cdot 200 \text{ MPa} = 120 \text{ MPa}$
 $\sigma_{CD} = \frac{15}{25} \cdot 200 \text{ MPa} = 120 \text{ MPa}$
 $\sigma_{DE} = \frac{15}{25} \cdot 200 \text{ MPa} = 120 \text{ MPa}$
 $\sigma_{EF} = \frac{15}{25} \cdot 200 \text{ MPa} = 120 \text{ MPa}$
 $\sigma_{FG} = \frac{15}{25} \cdot 200 \text{ MPa} = 120 \text{ MPa}$
 $\sigma_{GH} = \frac{15}{25} \cdot 200 \text{ MPa} = 120 \text{ MPa}$
 $\sigma_{HI} = \frac{15}{25} \cdot 200 \text{ MPa} = 120 \text{ MPa}$
 $\sigma_{IJ} = \frac{15}{25} \cdot 200 \text{ MPa} = 120 \text{ MPa}$
 $\sigma_{JK} = \frac{15}{25} \cdot 200 \text{ MPa} = 120 \text{ MPa}$
 $\sigma_{KL} = \frac{15}{25} \cdot 200 \text{ MPa} = 120 \text{ MPa}$
 $\sigma_{LM} = \frac{15}{25} \cdot 200 \text{ MPa} = 120 \text{ MPa}$
 $\sigma_{MN} = \frac{15}{25} \cdot 200 \text{ MPa} = 120 \text{ MPa}$
 $\sigma_{NO} = \frac{15}{25} \cdot 200 \text{ MPa} = 120 \text{ MPa}$
 $\sigma_{OP} = \frac{15}{25} \cdot 200 \text{ MPa} = 120 \text{ MPa}$
 $\sigma_{PQ} = \frac{15}{25} \cdot 200 \text{ MPa} = 120 \text{ MPa}$
 $\sigma_{QR} = \frac{15}{25} \cdot 200 \text{ MPa} = 120 \text{ MPa}$
 $\sigma_{RS} = \frac{15}{25} \cdot 200 \text{ MPa} = 120 \text{ MPa}$
 $\sigma_{ST} = \frac{15}{25} \cdot 200 \text{ MPa} = 120 \text{ MPa}$
 $\sigma_{TU} = \frac{15}{25} \cdot 200 \text{ MPa} = 120 \text{ MPa}$
 $\sigma_{UV} = \frac{15}{25} \cdot 200 \text{ MPa} = 120 \text{ MPa}$
 $\sigma_{VW} = \frac{15}{25} \cdot 200 \text{ MPa} = 120 \text{ MPa}$
 $\sigma_{WX} = \frac{15}{25} \cdot 200 \text{ MPa} = 120 \text{ MPa}$
 $\sigma_{XY} = \frac{15}{25} \cdot 200 \text{ MPa} = 120 \text{ MPa}$
 $\sigma_{YZ} = \frac{15}{25} \cdot 200 \text{ MPa} = 120 \text{ MPa}$
 $\sigma_{ZA} = \frac{15}{25} \cdot 200 \text{ MPa} = 120 \text{ MPa}$



WOOD

TECHNOLOGY & APPLIED STUDIES

This year our Yr 7 and 8 Design and Technology students have designed and constructed projects such as: cutting boards, multipurpose containers, serving trays, cd racking projects as well as the electronic projects of 'Over the Mountain' game, continuity testers and jewellery projects. During the course, students go through a design process, looking at reasons for choosing shape, construction methods and why certain materials are used. The students have developed very useful skills in the areas of designing, knowledge and in practical construction methods and use of tools using a variety of materials.

Wood Technics students in Years 9 & 10 gained skills in designing, construction and the use of tools and woodworking machines as well practical and theoretical knowledge during cabinetwork and wood machining.

The Year 9 students have constructed filing trays, a pot plant stand, step ladders, a variety of boxes as well as woodturning projects of a rolling pin and faceplate bowls from a beautiful coloured hardwood timber. The Year 10 students have designed and worked on their own projects. These range from tables and TV cabinets to book shelves.

The Yr. 9 & 10 electronics students have constructed a variety of projects varying in degrees of difficulty ; from moisture level indicators, logic probes simple 2 tone alarm modules and digital clocking and counting circuits in Year 9 to more complex circuitry such as the AM radio and remote control vehicles in Year 10.

Our Technical Drawing students demonstrated the high level of design and drawing skills that our students do develop in two years of TD. The Yr. 9 students progressed quickly, and were able to work in more advanced areas of the course; while the Year 10 students produced some high quality work.

The two Year 11 Engineering Studies classes were the first group through the new course. During the year they looked at the materials, mechanics, drawing and history of products in areas of bio-mechanical engineering, civil structures, bicycles, lawnmowers and household appliances. Next year they will study aeronautical engineering and telecommunications.

I would like to say a special thank you to our energetic, part-time casual teacher for the past two years, Ms. Mary Tracogna., who is leaving us this year.

**Mr. G. Osland
Head Teacher**



CAREERS REPORT

Pathways: The Class of 1999

Summary:

1. 160 students were eligible for the University Admission Index (UAI)
2. Of the students that applied for university, 97% of students were offered a university place, 152/156 students who applied for a university place were successful.

A summary of university offers:

The University of Sydney 60 offers, University of NSW 41 offers, University of Technology 25 offers, Macquarie University 18 offers, University of Western Sydney Nepean 4 offers, Southern Cross University 2 offers, University of Western Sydney Macarthur 1 offer, Monash University (VIC) 1 offer.

The University of Sydney offers (60):

10 Arts/Science, 2 Arts (Media and Communications), 1 Arts/Social Work, 1 Liberal Studies, 2 Combined Laws 1 Engineering/Arts, 1 Arts (languages), 5 Economics or Economics (Social Sciences), 3 Commerce or Economics (Accounting), 2 Social Sciences, 1 Applied Science (Nuclear Medicine), 1 Applied Science (Speech Pathology), 1 Applied Science (Exercise and Sport), 3 Computer Science and Technology, 2 Computer Science and Technology (Advanced), 1 Dentistry, 1 Education (Primary), 1 Engineering (Mechanical), 1 Engineering (Chemical), 1 Engineering (Aeronautical), 2 Engineering/ Science, 1 Engineering (Computer), 1 Medical Science, 1 Music (Jazz Performance), 1 Music Studies, 1 Nursing, 3 Science, 1 Science (Bioinformatics), 1 Science (Architecture), 1 Science (Molecular Biology and Genetics), 2 Science (Environmental), 1 Science (Marine), 1 Science/ Commerce or Science (Advanced) Commerce.

University of NSW offers (41): 4 Architecture, 1 Art Theory, 3 Arts (Media and Communications), 1 Arts/ Asian Studies/European Studies, 1 Aviation (Operations Management), 7 Commerce, 1 Commerce (Marketing and Hospitality), 3 Combined Laws, 1 Design (Industrial Design), 1 Engineering/Commerce, 1 Economics, 4 Engineering (computer), 3 Engineering (Software), 1 Engineering (Computer Science), 1 Engineering (Chemical), 2 Engineering/ Arts, 1 Medical Science, 1 Science (Medicine), 2 Science (Biotechnology), 1 Science (Computer Science), 1 Science (Psychology).

University of Technology offers (25): 1 Arts Communications (Journalism) and International Studies, 1 Arts Communication (Social Inquiry)/ Laws, 1 Arts Communications (Social Inquiry) and International Studies, 1 Art Communications (Social Inquiry). 1 Arts Tourism management, 4 Business, 3 Business/Laws, 1 Engineering (Civil and Environmental) Dip.

Engineering Practice, 1 Engineering Computer Systems Dip. Engineering Practice, 2 Engineering/Business, 1 Business Information Technology, 1 Laws/Arts in International Studies, 4 Science (Computer Science).

Macquarie University Offers (18):

1 Applied Finance, 1 Applied Finance/Laws, 2 Arts(Media & Cultural Studies), 1 Arts (Psychology), 1 Business Administration, BusinessAdministration/Laws, 1 Commerce or Economics (Accounting), 1 Commerce (Actuarial studies)/Applied Finance, 2 Commerce (Actuarial Studies)/Applied Finance/Economics, 1 Commerce (Actuarial Studies)/Laws, 1 Commerce (Actuarial Studies)/Science (computer/maths/statistics) 3 Combined Laws, 1 Science (Advanced Biology), 1 Science (Biodiversity and Conservation).

University of Western Sydney, Nepean offers (4):

2 Arts (performance), 1 Computer Science/software Engineering), 1 Engineering (Computer).

University of Western Sydney, Macarthur offers (1): Psychology.

Southern Cross University Offers (2): 1 Business in Tourism, 1 Education (primary).

Monash University offer (1): Medicine.

Other career options of the 8 students not going to university:

1 Childcare, Petersham TAFE, 2 students are repeating the HSC (1 at TAFE and 1 at a high school); 1 TAFE Business Course, 1 Plumbing Apprenticship, 1 Southern Cross Exchange to Japan, 1 volunteer worker and one seeking employment.

Scholarships in 1999

Congratulations go to the following students for receiving scholarships from the 1999 HSC:

1. Sarah Johnson, a Co-op Scholarship to study actuarial studies in a Commerce Degree at UNSW valued at \$11,150 per year over 2.5 years and then including paid industrial experience.
2. Justin Tsuie, a Co-op Scholarship to study Information Systems and Management in Commerce Degree at UNSW valued at \$11,150 over 2.5 years then including paid industrial experience.
3. Joey Le was awarded a Sydney University Undergraduate Scholarship valued at \$5,000 per year over five years as he studies Engineering/Science.
4. Steven Hwang, a Business Information Technology Scholarship at the UTS valued at \$11,000 per year over three years.
5. Peter Chen, a Macquarie University Innovation Scholarship to study Actuarial Studies valued at \$2,000
6. Andrew Bishop, a \$3,000 Scholarship from the
7. Toby Allen, a scholarship to study Telecommunications Engineering at Sydney University.

CAREERS REPORT

TAFE Customer Service Course.

Michelle Jersky ran this course at school. The course explained how to deal with people from different countries and people with a disability. Many students have used their certificate to gain part time employment.

UNSW University Representative visit Fort Street.

Co-op Scholarships at UNSW offer students the opportunity of an \$11,000/year tax free scholarship and industrial experience. In 1999 two Fortians won a Co-op Scholarship: Sarah Johnson and Justin Tsuei.

A member of the student recruitment team at UNSW visit the school each year to discuss tertiary options with year 12 students.

Vocational Education

Peter James of Year 12, 2000. Peter is the last Fortian to complete the Joint Secondary Schools TAFE Course. He attended Ultimo TAFE and completed a one unit Computer Technician Course. These courses have been replaced by two unit courses with the introduction of the new HSC. Therefore Fort Street has ceased involvement in vocational education.

Sydney University Events

Sydney University has introduced school visits to the university campus. Apart from the two university representative visiting Fort Street to discuss course and career options, Jack and Rocky opted to spend two hours touring university campus (outside school hours) with the two guides from the Student Recruitment Unit. It provided an excellent opportunity to collect information and consider future university courses and career plans. I hope more Fortians pursue this opportunity in 2001.

UTS connections

Tilda Sikes from the Student Recruitment Unit at UTS with year twelve students. These school visits are a great opportunity to evaluate career courses and options

The UTS Women in Engineering Program run by UTS on May 10 was attended by Janelle Espinas, Shaily Aggarwal, Sarah Ho, Sahra Behardien, Jose Rauya, Jenny Gray, Alix Nicholson, Elise Chen, Sheryl Soo and Noola Goel. Fortians have been attending this day for over ten years.

This was an entertaining event: building a structure from paper that would house the group.



Sahra and Janelle look on as the finishing touches are added.

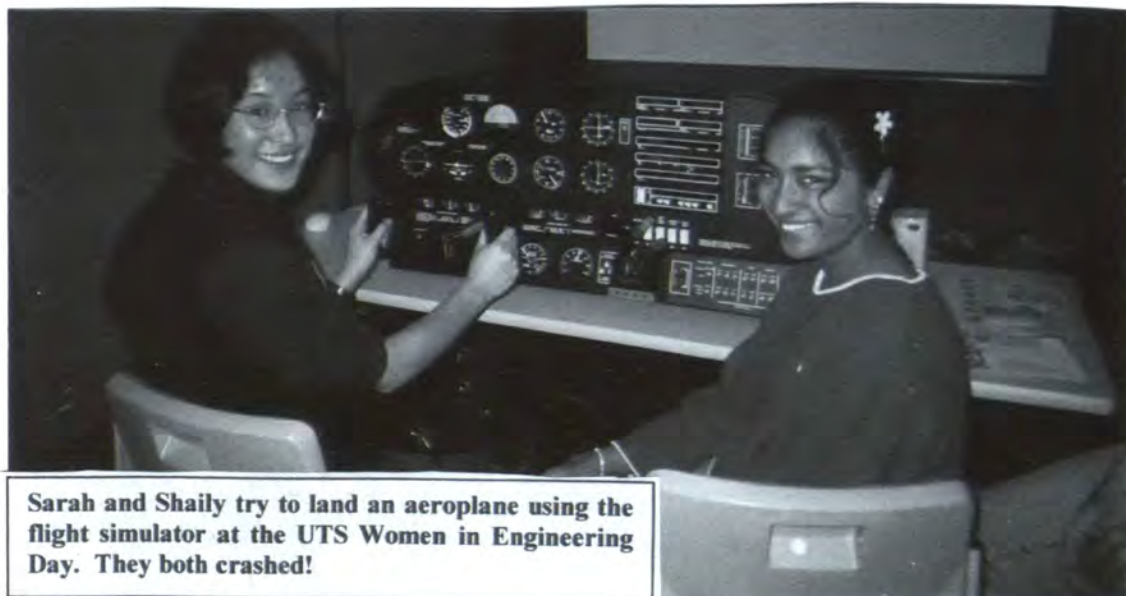

Sarah and Shaily try to land an aeroplane using the flight simulator at the UTS Women in Engineering Day. They both crashed!

Australian Defence Force Academy.(ADFA) Spring Engineering School in Canberra.

Congratulations to Gerrard Serisier of Year 11 for being one of the 40 students selected to attend this event over the week of 18-22 September. The purpose of the visit was to introduce students to different Engineering faculties and associated academic department at ADFA. Gerrard was flown from Canberra and provided with accommodation while all meals expenses were paid for by ADFA. This was a jam packed week of visits, workshops, lectures and social activities.

2000 Honeywell Engineering Summer School (HESS)

HESS was run from Sunday December 10- Friday 15 and attended by David Sun of Year 11. Congratulations must be offered to David who was selected to attend this summer school. He was in great company as only 80 students from the ACT and NSW were in attendance.

Students met and interacted with professional engineers employed by the government, private companies, research and academics in a wide range of disciplines. The program was presented by Honeywell Limited. The Institute of Engineers Australia, University of Western Sydney (Nepean), University of NSW. University of Sydney. University of Technology, University of Wollongong and Rotary International. Rotary partially subsidised the attendance cost of \$450 for David. Thank you.

In recent years two Fortians attended this Summer School after being endorsed by our neighbourhood engineer, Mr John Hopman. Mr Hopman recently visited the school and gave a presentation to a number of Year 10 students about his involvement in engineering. He is keen to interview any Year 12 students considering engineering as a career.

School Partnership with Macquarie University.

Last year Fort Street High School joined the Macquarie School Partners Program. The benefits of this program are set out below. However, the benefits need not be confined to those set out here. The University invites suggestions from the school to strengthen the relationship, to foster the partnership.

The Macquarie School Partners Program comprises:

Academic prizes: The Universities has agreed to endow a prize for the best student to enter the University each year. This means it is a permanent speech day prize from now on.

Library Donation: A book will be presented that has been published by a Macquarie academic to our library annually.

Scholarships:

As a School Partner we can nominate candidates for Macquarie School Partners Scholarships. The competitive scholarships valued at \$2,500 each are only available to Year 12 students. They will be awarded on the basis of academic achievement, sporting achievements at school with a commitment to represent the University in their chosen sport.

Community Service Awards:

These will recognise seniors who have made outstanding contributions to the community. Awarded for the first time in 2000, the Awards will be in the form of a certificate commemorating this recognition and a voucher to the value of \$100 for the purchase of books from the University Co-operative Bookshop. The inaugural award is currently being considered.

University Experience:

Students will be offered opportunities to sample university lectures and university life. Some Fortians have already participated in this program.

David Ng wins a United World Colleges Scholarship

David signed out of the school in August this year to head off to Hong Kong to study for the International Baccalaureate. This rather confronting decision has meant that he has withdrawn from all 2000 HSC subjects before his HSC except Engineering Science. He will sit for Engineering Science in Hong Kong. David's scholarship was valued at over \$44,000 and covers 80% of the costs of board and tuition over the next two years.

David Ng, the winner of the United World Colleges Scholarship, 2000.



David's success is a testimony to his outstanding extracurricular involvement in the school community. Two of his most noticeable achievements were in the School Council of 1999/2000 and the Young Achievers Business Skills Program of 1999. The School wishes him all the best and we do hope he will come back to visit and tell us of his adventures. After his study, David has the option for applying to five Universities in the USA and if successful will have all tuition, accommodation and other living expenses paid for from a \$45 million scholarship trust that has been established. This is really the opportunity of a lifetime.

David is the sixth winner of a United World College Scholarship since 1995. This is an outstanding Fortian record.

Postcard from Hong Kong:

" A component of life here in Hong Kong is community service. I wanted to do coral monitoring which involves scuba diving with all training included, but it was a two year commitment instead of a term commitment. I decided to pick practicing English with local school students instead. Next Saturday is China Week for all first year students. I've chosen to go on the Yao Tribe Project where we venture to the mountains in Northern Guangzhou to spend a week with the tribe. I've heard from second year students who went there that they know nothing of the outside world including the existence of countries like Japan. I dunno....I'm very concerned that by visiting we'll be contaminating their simple and contented existence".

Part of an e-mail from David in October 2000

Time rock

For long I've lived
 In peace and in war
 When children come playing
 When bullets come raining
 For I'm a hard red, heart red, red ochre rock
 But my time like all mortal things
 Has an end
 When the earth starts bleeding
 It's boiling scarlet blood
 I will follow
 And become it's fiery doom
 Ashes to ashes, dust to dust.....

By Weily Zhang Yr.7

Ker Zhang off to the USA

The school wishes Ker the best of luck as he heads off to the USA to study Arts.

"It is a sad moment for me to leave Fort Street, especially when I am flying all the way to America. Watching my friends study hard for the HSC, I feel guilty for the chance to relax and have fun.

It all began when I applied for the University of Southern California late last year. I saw it as a chance to gain new experiences, develop new friendships and open my eyes to new opportunities. By March it became a reality when I was accepted to attend the USC.

The application process was gruelling and took almost a year. I had to sit for the SAT(this is the American version of the HSC) Although I had to apply to each University individually and write numerous essays it was all worth it.

I will now embark on a new path so Goodbye Fort street and godlike."

Ker Zhang, Year 12, 2000.



Jamie Cameron

Encore is a selection of exemplary HSC music performances and compositions. It is a celebration of the outstanding talent of singers, instrumentalists and composers from schools throughout New South Wales. *Encore* is presented by the Board of Studies NSW and NSW department of Education and Training and is produced by the Performing Arts Unit.

Jamie Cameron was chosen to be the opening item for *Encore 99*. He performed "Antiphon for two Drummers" by Sarcich with Fort Street High's drum tutor, Martin Highland. These notes are taken from the *Encore 99* program, which was performed early in 2000.

Jamie Cameron chose to study performance skills. He completed where he studied 3 Unit Music. was five years old and drums since various ensembles, music camps, accepted to study for a Bachelor of Conservatorium of music and music.



music for the opportunity to enhance his his Higher School Certificate at Fort Street Jamie has been playing jazz piano since he he was six. Jamie has participated in stage and concert bands. Jamie has been Music in Jazz Studies at the Sydney hopes to make a living from playing

Trish Donohue

OUR PIANIST'S FAME



On the second last day of the '100 day Sydney Torch Relay, Liam Tong ran as an Escort Runner with the Olympic Flame. Soon after this Liam received his A.Mus.A. (Associate Diploma in Music) from the Australian Music Examinations Board for piano. Liam is in Yr.11 and is studying the extension course in music, majoring in performance for the HSC.

MUSIC REPORT - 2000

The new Millennium has seen an ever increasing number of successes in Music both academically and in performance. Classes from Year 7 to, 12 experience a variety of workshops, concerts and excursions in their quest for further knowledge about the exciting world of music.

The HSC class of 2000 has been perhaps the most successful at Fort Street in many years. Holly Malaquin achieved outstanding success in 3 Unit Music in being nominated for the "Encore Showcase Concert" conducted by the Board of Studies. Holly, playing the flute, performed at a very high standard and we have our fingers crossed that she will make the program for this event and perform at the Opera House in February, 2001.

Similarly, Mac Shine also received a nomination for this event for his performance on percussion. These two students follow in the footsteps of Jamie Cameron (Class of 1999) who opened the program at this concert in February, 2000. The teachers of the Class of 2000, Mrs Trish Donohoe and Mr Jon Suffolk are extremely proud of their students' successes and would like to extend their thanks to the I.M.P conductors Mr Phil Harper, Mr John Ockwell and Mr Martin Highland for their contributions to these students music education.

Nick Osborne was also acknowledged as an outstanding musician. Nick's Viva Voce at the HSC was identified as an 'exemplary work'.

Three students from the Year 11 Class of 2000 have been selected as members of the Sydney Youth Orchestra for 2001. Holly Phillip (percussion), Marcus Coleman (Cello) and Jeremy Sung (violin) will join the orchestra in February and undoubtedly be involved in making music at the highest level. The orchestra will tour Europe in 2001.

Paul Young (Yr.10) and Jennifer Ahn (Yr.9) are to be singled out for special mention. These two outstanding performer presented solo items at the Sydney South East Region Music Festival. Their commitment to music making of the highest degree is to be congratulated.

Students who study music also attended workshops by performers such as Eddie Qansar (African Drumming), Bill Nelson (Music Technology) and Andrew Ox (Saxophone). A small group of senior students also worked with the composer Mark Isaacs on an original composition based on the theme of 'The River'. This group composition was entered into a national composition.

Overall it has been another exciting and busy year in the Music department and 2001 appears to contain the

same level of participation by staff and students in the developing music scene at Fort Street.

Fortians Join the Sydney Youth Orchestra

Marcus Coleman, cellist who has been a member of the Sydney Youth Orchestra for some time, has been joined by two of his classmates from the Year 11 music class in the prestigious Sydney Youth Orchestra. Two new additional members (as shown in the photograph below): Holly Phillip, percussionist, Jeremy Sung, violinist, both auditioned against some of the best young performers in the State in order to gain a place in the orchestra.

The Sydney Youth Orchestra will have many important engagements during 2001 including a tour of Denmark. What a wonderful experience this will be for our three Fortians who are taking the extension course in music, majoring in performance for their HSC.

Jon Suffolk – Music

Jeremy Sung & Holly Philip – New Members of Sydney Youth Orchestra



AUSTRALIAN BUSINESS WEEK

The Australian Business week experience is one I will never forget. The business enterprise world really offers so many amazing opportunities for career development. Australian Business Week (ABW) is one of the most realistic learning experiences available for school students in Years 11 and 12. It is supported by the State Department of Education, universities and major corporate businesses today. ABW provides students with the opportunity to learn about business from the business perspective by working with business people. The unique aspect of the program is that it doesn't focus simply on urbanised students but really offers the entire state of NSW the chance of experiencing the business world. I was only one of approximately 35 students from the Sydney region, out of 80 students statewide.

Between the 26th and 30th of June, I was accommodated both night and day at the St. Andrew's College on the University of Sydney Campus in Newtown. It was the first ABW and was hosted by the first University of Australia. The college was quite remarkable in its history and was also well facilitated including the absolutely scrumptious food (unlike other camp food I've had!). Over the next week I was to endure five long 15 hour days beginning at 6 am, finishing at 11 p.m. running on an intense and strict timetable of events. I was placed in the company of ten students with seven other companies competing against my own. Each company assigned two mentors - one from a major business sponsor company and the other a Social Science teacher from a high school in NSW. We were presented a challenge, to simply be the best.

The aim of ABW is to gain an insight into the world of business by fostering the important skills of teamwork, leadership and entrepreneurship. We did this by taking over an established computer simulated company and assuming the role of the company's employees. In addition we were required to mount a trade display, make a 30 second video advertisement, write a company report and also deliver an oral presentation. Elections were held for the position of Chief Executive Officer (CEO) in each company and position in Corporate, Marketing, Operations teams to decide upon. One of the major activities during the course of the week was our challenge to run our company for a simulated 2 year period in competition against the other participating companies. We all made critical decisions which affected our company's performance in the market place, a model of the Australian economy. The 54 intense decisions made each quarter determined the price, volume, distribution, advertising, quality, staffing, funding, marketing strategy and production processes, etc.

Our first two days consisted mostly of lectures which detailed the events of the week as well as to prepare us adequately with information to aid us in our business tasks. These were perfectly balanced up with our favourite time of the day- Coke breaks. As Coca-Cola was one of the major sponsors, we were all provided with an unlimited access supply to Coca-Cola manufactured drinks. Everybody was loaded up with caffeine to keep us awake over the next lengthy week! The rest of the week was spent making decisions and planning our business responsibilities. The program had been cleverly designed to incorporate team building encouragement activities with at least one major activity per day. These included team karaoke(!!!), Corporate Athletic games, Theatre Sports, Queen of Sheba, orienteering and other enjoyable activities. We also got up every morning at 6 am to head off to the sporting facilities of the University of Sydney to ... believe it or not... exercise!

With such a well rounded program it was easy to maintain our spirit and hopes, although there were many times where the pressure mounted. There were deadline's to meet and executive meetings to attend, however, by the end of the week most of us were aware the pressure would be there for the duration. Another incredible aspect of the program I found was the inspiring talent that had managed to gather around the state. It was so wonderful to be able to work as a part of a team with nine other intelligent, ambitious and confident teenagers who had hopes and dreams similar to your own. There was even one boy, who took down the contacts of everybody participating in the program, welcoming them to help him start his very own business after the HSC!

Overall I will never forget my experience at Australian Business Week. The program was inspiring, enjoyable, but most importantly, realistic. "Some things you just can't learn unless it's through experience". ABW is a perfect example of this. For one week, students really are given the chance to simulate a real company and do all the things real businesses do. The program adequately teaches you how to complete these tasks as well as balance your entertainment with teamwork activities. Those who have had the exceptional ABW experience will, no doubt, have developed an insight into the world of business and with this, I believe when it comes to our own careers in business, anything is possible.



Wendy Tu
Year 11

EIFUKU HIGH SCHOOL VISIT TO FORT STREET

22nd July -5th August

This year marked the seventh visit to Fort Street by our sister school Eifuku HS. As with previous visits, this occasion proved to be very successful and afforded our students an opportunity for cross cultural exchange.

The Eifuku students were able to enjoy home stays among Fort Street families and were able to observe our school life in all its varied aspects. They travelled further afield, their main excursion being a trip to Canberra. There were also day trips to the Blue Mountains and to Manly, both of which were greatly appreciated by our guests.

The Eifuku group was ably led by Mr Furukawa, scientist and master of amazing feats of magic, called Handpowers, and by Mr Kitakado, a debonair Bon Viveur, master of English language and Japan's answer to 007.

An exchange visit takes considerable organisation and co-operation between staff and students. First and foremost however, grateful thanks must be extended to those Fort Street parents who offered home stays. Without the sympathetic and enthusiastic participation of Fort Street parents the exchange program simply could not exist. Heartfelt thanks also to the teaching staff whose co-operation was vital to a successful visit.

Many thanks to Mr Greg Talbot and Mr Glen Tippit for organising the excursion to Canberra. Thanks also to Ms Toula Bull for yet again giving of her time to organise special English lessons for our visitors. Deepest gratitude to P&C representatives Mr John Barber and Ms Sharon Doolan who spent an entire day taking the Eifuku students on a city tour which included the Opera House, the Botanical Gardens, and The Rocks, and many thanks to Ms Lynne Trevini for her cheerful presence at the Manly excursion. Thanks also to Mr Geoff Vitlin, P&C Chair for the speech at the Welcoming Ceremony.

This year 2001, it will be Fort Street's turn to visit Tokyo for the seventh time. Many students have already expressed an interest in going on the trip. It is an excellent cross cultural experience and of all the students who have participated in the past visits not a single one has ever returned disappointed.

**Co ordinator -Fort Street- Eifuku exchange program,
Serge Yalichev**



**Peace and Love - from our sisters from
Eifuku High School on visit to Fort Street**

MEG REPORT

This Olympic year has been a great one for the Mathematics Enrichment Group (MEG) at Fort Street. The main purpose of joining the MEG is to motivate, stimulate and develop our mathematically interested and talented students. This has certainly been achieved and is evident from our results.

MATHS CHALLENGE

The 2000 Maths Challenge, a competition run by the Australian Mathematical Olympiad Committee (AMOC), is an integral part of the MEG Program in our school.

The 2000 Maths Challenge consisted of six problems that were completed over a three-week period in April and May. Four of the problems were attempted individually while pairs of students could discuss the other two before submitting their individual solutions.

In the Junior Division (Years 7 and 8), the results showed 7 High Distinctions, 19 Distinctions, 21 Credits and 18 Participation. In the Intermediate Division, there were 8 High Distinctions, 10 Distinctions, 6 Credits and 2 Participation. It is worth mentioning that **Chau Tran** in 7F earned full marks in this competition!!

INTERMEDIATE DIVISION

High Distinction: Xiang Yuan (Tommy) CHEN(10M1), Enoch Chee Lok LAU (9M2), Yun WANG (9M1), Vineeth CHIPPADA (9M2), Catherine FENG (10M3), Dang Thuan HO (9M2), Janet AN (10M1) and Jensyn LUC (9M1)

Distinction: Jason CHAN (9M1), Angela WEN (9M2), Minh Nguyet (Gina) DANG (9M2), Zuo HUANG (9M2), Louis HUYNH (10M1), Tim LAM (9M2), Max WANG (9M1), Teresa CHOI (9M1), Kevin HA (9M2), Sarah HO(10M1)

Credit: Thomas HUYNH (10M1), Yue (David) JIANG (9M3), Devesh SHARMA (9M2), Felix HONG (10M1), Varun SAHNI (9M4), Jim Zicheng DING (9M2)

JUNIOR DIVISION

High Distinction: Chau Hung TRAN (7F), Jessica CHEN (7F), Ricky MENG (8T), Lillian CHAIN (8T), Lacramioara NACU (7R), Robert SHI (8I) and Maciej SLUSARCZYK (7T)

Distinction:

Ramana CHANDRABALA (7R), Shirley CHEN (7F), Ryan CHUI (8T), Alina KOZLOVSKI (7R), Nicholas LEUNG (8O), Lin WANG (8I), Anna KOPYCIOK (7I), Steven SHI (8F), Justin SUI (8O), Joe (Chong) XIE (8O), Clara CHUNG (7I), Felix HANG (7R), Raymond LI (7F), Steson LO (8I), Christine LU (8T), Viet NGUYEN (7R), Owen TONG (7F), Tracy WONG (8R) and Lily ZHANG (7F)

Credit: Paul CHAN (8T), Pan CHEN (8T), Vicki LOWE (8T), David MAO (8F), Kieran OWENS (7I), Bing Yibin YOU (7F), Stephanie CAIRNS (7O), Joyce (Aimee) CHAU (8T), Nirushan RAVEENDIRAN (8R), Peter SHI (8I), Kevin SIU (8O), Mandy LEUNG (7F), Mary WANG (7F), Rose WANG (7F), Carrie YANG (7F), Marina CHEN (7F), Gokulan KARUNASALADEVA (7O), Charlene KO (8O), Milton LAI (8F), Danny TAUU (8F), Nadia WONG (7F)

The above results indicate that our school team ranking score range is 85 – 90 in both the junior and intermediate division putting it within the top 9 % of the state.

This year the Mathematics Faculty offered prizes to the High Distinction award winners. Well done to all participants

MATHS ENRICHMENT STAGE

Some of our talented junior students participated in the very demanding 2000 Maths Enrichment stage which consists of the following four different parallel series:

EULER SERIES is designed for year 7 students and contains 12 miscellaneous challenge problems on elementary number theory, counting techniques, work on areas, pigeonhole principle and logic.

High Distinction: Chau Hung TRAN (7F), Lacramioara NACU (7R) and Mary WANG (7F)

Distinction: Vivienne TRAN (7F), Alina KOZLOVSKI (7R), Carrie YANG (7F) and Maciej SLUSARCZYK (7T)

Credit: Kieran OWENS (7I), Lily WANG (7F), Rebecca DIEP (7R), Fiona WU (7F), Rose WANG (7F), Lily ZHANG (7F), Marina CHEN (7F), Damian FOX (7R), Jenny LY (7F) Annie DOU (7F), Gokulan KARUNASALADEVA (7O) and Shirley CHEN (7F)

M.E.G. REPORT.....

GAUSS SERIES contains 12 problems which develop problem solving techniques such as counting and the use of spreadsheets designed for year 8 and year 9 students.

Both the Euler and the Gauss series ran from 31 May until 16 August 2000.

Distinction: Varun SAHNI (9M3)

Credit: Zuo HUANG (9M2), William WONG (9M3), Wei (Ricky) MENG (8T)

Joe (Chong) XIE (8O), Steven SHI (8F), Susan SU (8R), David MAO (8F) and Kevin SIU (8O)

NOETHER SERIES contains 16 problems on problem solving, algebra, geometry and number theory and is designed for students in years 9 and 10 who have already attempted the Gauss Series.

High Distinction: Enoch LAU (9M2) and Yun (Kevin) WANG (9M1)

Distinction: Max WANG (9M1), Liu SHINUO (9M2), Vineeth CHIPPADA (9M2), Jim DING (9M2) and Dang Thuan HO (9M2)

Credit: Colin DING (10M1), George NG (10M1), Sarah HO (10M1), Tim LAM (9M2) and Devesh SHARMA (9M2)

POLYA SERIES This demanding series contains 16 problems on Euclidean Geometry, Deductive Reasoning and Algebra and is mainly designed for Year 10 students. Both the Noether and Polya Series ran from 31 May until 6 September 2000.

Credit: Xiang Yua (Tommy) CHEN (10M1) and Brian DIEP (10M1)

Overall, we received 4 High Distinctions, 10 Distinctions and 28 Credits. A tremendous effort and commitment from all participants!

MATHSEARCH

This J.L. Williams Competition is for the very able Year 11 students who are capable of working independently on a take-home project involving an exploration of an unfamiliar area of Mathematics.

The duration of the project was two weeks including 3 weekends ending on 20/5/2000.

Both participants **Ben Poon** (Year 11) and **Tommy Chen** (Year 10) received Merit Awards in this competition.

THE 2000 AUSTRALIAN MATHEMATICS COMPETITION

More than 487,000 secondary school students from 36 countries entered this year's Competition, 402,000 entrants were from Australia. Established in 1978, the Competition has been popular with students ever since. Because it's fun, most students actually look forward to "giving it a go" and use their certificates of achievement in the future when applying for jobs.

The Australian Mathematics Competition was held at the beginning of August. Fort Street High School entered 612 students in the Competition.

Our prize-winners were **Nishad Kulkarni** of Year Eight, **Enoch Lau & Thuan Ho** of Year Nine, **Colin Ding, Bobby Jang, Davy Lei & Tommy Chen** of Year Ten and **Lee Kim & Chris Son** of Year Twelve. **Enoch Lau** will also receive the Special Achievement Certificate for Best Standardised Score and least number of wrong answers for Fort Street High School. **Nishad Kulkarni** was successful in being chosen to participate in the AMT Junior Correspondence Enrichment program. All prize-winners have received their cheques, awards and certificates at a special school presentation.

A summary of results is as follows:

All students have already received either award certificates or certificates of participation with an individual performance report.

Year	No. Entered	Prizes	High Distinctions	Distinctions	Credit
7	145	0	13	55	65
8	101	1	12	44	35
9	116	2	12	49	46
10	104	4	7	52	35
11	95	0	2	31	45
12	51	2	2	21	19

Thanks to Mr Hilaire Fraser, the AMC Coordinator, for his excellent organisation of this successful competition.

M.E.G. REPORT.....

THE AUSTRALIAN INTERMEDIATE MATHEMATICS (AIMO)

The Australian Intermediate Mathematics (AIMO) is the third stage of the Mathematics Challenge for Young Australians. This is a four hour test that was held on the 10th of August for students interested in a further mathematical challenge.

The questions are mainly based on work which requires no background, except some questions on euclidean geometry; other questions involve number theory, counting techniques and logic. Hence the participants are generally good at mathematics and have demonstrated problem solving ability.

Of the 17 students who attempted these questions 7 were successful in being chosen to participate in the Correspondence Enrichment Program. They are the recipients of the High Distinction and Distinction awards.

High Distinction: Tommy Chen (10 M1), Enoch Lau (9M2), Yun (Kevin Wang (9M1), Stephen Bernard (10M5), Thuan Ho (9M2).

Distinction: George Ng (10M1) and Zuo Huang (9M2).

Credit: Vineeth Chippada (9M2), Brian Diep (10M1), Catherine Feng (10M3) and Max Wang (9M1)

THE UNIVERSITY OF NSW 39TH ANNUAL SCHOOL MATHS COMPETITION

The University of New South Wales has conducted a Mathematics Competition for secondary school students in New South Wales and the A.C.T for the last 38 years.

Considerable interest in Mathematics is aroused by this competition which is designed to assess mathematical insight and ingenuity rather than efficiency in tackling routine problems.

The Competition takes the form of a three hour examination and was held on Tuesday 13th June in room 28. Overall, 27 students from our school sat for this competition. The following is a list of all participants.

Senior Division: Rocky Lam, Helen Jin, Fei Yu, Jing Jing Li and Chris Son from Year 12.
Mithilesh Dronevalli, Duc Ho and Anh-Thu Le from Year 11.

Junior Division: Brian Diep, Tommy Chen, Louis Huynh and Ran Tao from Year 10.
Zuo Huang, Jin Yang Qian, Enoch Lau, Kevin Wang, Simon Sheikh, Geoff Lai, Michael Yu, Jack Wu and Max Wang from Year 9.

In The Junior Division **Zuo Huang** (9M2) was awarded a prize and certificate in a ceremony held in the Sir John Clancy Auditorium, the University of New South Wales, on Thursday 31st August.

Moreover **Tommy Chen** (10M1), **Louis Huynh** (10M1) and **Jing Jing Li** (Year 12) were awarded certificates for excellent achievement in this competition.

On behalf of the Mathematics Faculty and the whole school, we would like congratulate all our prize, award winners and participants for their efforts and commitment. Thanks to students, parents and teachers for your support and continued interest in the MEG activities and competitions which is integral to our success and we appreciate your efforts.

G. Rezcallah,

**Maths Enrichment Coordinator,
Maths Faculty.**



**Ralph Dixon Yr.7 gets 'the good oil' from
Mr. Hilaire Fraser (Maths staff member)**

SOCIAL SCIENCE

2000 has been a hectic but rewarding year for the Social Science Faculty. Results in the 1999 H.S.C were most pleasing with outstanding achievements in Economics, Geography and Legal Studies. The staff have been very busy implementing the new Junior Geography syllabus in Year 7, 8, and 9. 2001 will see this new program carried through to Year 10 with a greater emphasis on teaching of citizenship and democracy and an external examination in Geography for the School Certificate in 2002. Our students will also sit the New H.S.C next year. All this had a dramatic impact on what students learn and how they learn, and has been a major challenge for the staff.

The faculty encourages students to participate in extra curricular activities, which enables them to develop and utilise the skills they have learnt in the classroom. Some of these activities include:

- The Australian Geography Competition in which we had great success with Gaurau Johri and Damian Thomas (Year 11) receiving top scores in the state, but unfortunately they were ineligible to proceed o the Nationals due to their birth dates.
- Wendy Tu of Year 11 was our inaugural participant in the Australian Business Week Program. This was a most successful venture (see Wendy's report)
- Belkis Mereles of Year 11 was an enthusiastic and committed delegate to the N.S.W Constitutional Convention in Sydney in November 2000. She has been selected to attend the National Convention in Melbourne in March 2001.
- Our Mock Trial Team (Dip Hor, Wendy Tu, Belkis Mereles, Tarah Relativio, Shannon Lardi, Keith Tang, Michelle Woods, Lina Jang and Alan Shen), coached by Mr J Glass of Kemp Strang and Ms M Johanson, performed brilliantly in 2000 completing the season with a good win over Sydney Grammar.
- A group of Year 11 Legal Studies students were fortunate enough to attend the lunch of Fortian, Justice Michael Kirby's book ' Through the World's Eye' at Parliament House Sydney. A highlight of the occasion was an extended and humorous

conversation with the former Prime Minister Gough Whitlam (see report).

- Other activities pursued during 2000 include the Stock Market Game, the Australian Economics Competition and the N.S.W Governor Phillip Awards for Fieldwork.

Fieldwork continues to be an integral component of our courses, enriching glasswork, for example:

- Year 8 Geography enjoyed a Darling Harbour Walk in the sunshine but their Harbour Cruise was more like a visit to Wet and Wild.
- Year 9 Geography visited the Imax Theatre and the Powerhouse Museum.
- Year 10 Geography and commerce enjoyed visits to Canberra, Sydney Airport, Botany Bay, The Law Courts and the Police and Justice Museum.
- Asian Studies students had many wonderful experiences including visits to the Art Gallery Chinatown and the Chinese Gardens
- Year 11 Geography benefited form visits to Windsor and the Hawkesbury, Bicentennial Park (wetlands) and Pymont/CBD to study changing urban dynamics.
- Year 12 Geography completed their mandatary fieldwork in the Hunter Valley.

My thanks to all those teachers who organised the relevant and successful activities.

This year finishes on a sad note with the retirement of Ms Anne Draper. Anne came to Fort Street in 1986 and in 1990 she worked to have Legal Studies included in the curriculum. She has been an inspiration to her students through her extensive knowledge and love of the subject. Anne will be greatly missed by the Faculty and the School. We wish her well in her retirement.

MARIE JOHANSON
H/T Social Sciences.

LEGAL STUDIES STUDENTS VISIT JUSTICE MICHAEL KIRBY

On Wednesday 7th June the top Legal Studies students from 1999, and I were invited to visit Justice Michael Kirby in his chambers in the Supreme Court in Sydney, for afternoon tea.

The top students were:-

Terence Chu (winner of the Justice Michael Kirby Prize for 3 unit Legal Studies), Claresta Seto (2nd in 3 Unit Legal Studies), Anna Kim (3rd in 3 unit Legal Studies), and Nancy Tchou (3rd in the State for Legal Studies) .

The Judge, as usual, was a charming and entertaining host and soon put everyone at ease. He invited a Fortian from 1994 to join us, Simon Fitzpatrick, who had just been awarded the University of Sydney Medal for Law and was currently working as Associate to the Chief Justice of the High Court. Simon certainly was a wonderful role model for the students - three of whom, are studying or planning to study Law. When the Judge asked Simon the secret to his success, Simon had said that he had just found something that he really loved. He found the Law interesting and it was something for which he had an aptitude for. The Judge was very proud of the achievements of Simon and of Felix Ho, also a Fortian from 1994, who had just been awarded the University of NSW Medal for Law. What an honour for Fort Street!.

Justice Kirby is very keen for another Fortian to join the Bench of the High Court. Fort Street has produced four of the forty-three Justices of the High Court:-

Edmund Barton, H.V Evatt, Sir Garfield Barwick and Michael Kirby. Two other schools (both private) have also produced 4 Justices of the High Court each. Justice Michael Kirby is vert keen for Fort Street (a public school) to take the lead on it's own.

During afternoon tea, the Judge was very interested to hear of the students' areas of study and their career aspiration.

He spoke with pride of Fort Street and remembered fondly his days here. Coincidentally he was having a dinner that night with six of his colleagues from the class of 1955 when he told us how he thought that one of his colleagues, a chauffer, felt slightly ashamed that he hadn't reached greater heights in his career. However as the Judge pointed out to the students, he felt it was far more important that a person be happy in their life and be a "good" person i.e. someone concerned about the welfare of others, social justice and human rights. Only these people could truly be termed 'successful'.

Justice Kirby then asked if any of the students had any questions and Nancy, rather cheekily, asked for some help with the Law assignment she was doing. The judge consulted a few books, gave her some advice on how to approach the assignment and even suggested she could put down as one of her references 'Mikey Kirby'

The judge was also keen to point out to the students how fortunate they were to have gone to a great public school such as Fort Street and how important it was for all of us to support the public education system.

After a quick photo session and the signing of the visitors book, the students and I took our leave. The Judge told he was looking forward to visiting Fort Street at some stage and addressing the students . Justice Michael Kirby is a warm , compassionate and caring person and I believe the students at Fort Street will indeed be fortunate to hear him speak.

Fort Street students would have to search far to find a better role model than Michael Kirby - someone who embodies the true Fortian Spirit

ANNE DRAPER

Legal Studies Teacher 2000.

JUNE 2000

3 Unit Legal Studies Students of 1999

Nancy Tchou, Claresta Seto, Justice Michael Kirby, Anne Draper, Terence Chui, Anna Kim and Simon Fitzpatrick (Fortian just awarded The Medal for Law, Sydney University.



CONSTITUTIONAL CONVENTION

On the 20th November, I went to the State Schools Constitutional Convention held in NSW Parliament House. Delegates to this Convention were selected from various Metropolitan conventions held earlier this year which I also attended in Blacktown Chambers. After all the 150 students from around NSW settled down, the Hon. John Murray had the honour of welcoming the students and officially opening the convention.

Students were allocated to groups, and the groups had to discuss a general proposition and a specific proposition assigned to each group. The general proposition we were asked to consider was "A century later, can we still say that Federation was a good idea?" Two speakers were invited to share their views. Elaine Thompson, Associate Professor (School of Politics and International Relations UNSW) and Peter Botsman, Executive director Brisbane Institute. Ms Thompson deeply favoured Federation while Mr Botsman was strongly against it. It was very interesting hearing both sides of the argument because both had numerous valid points.

My group was asked to discuss the question 'Will the Australian Constitution work for the 21st Century?' Students had to conduct a discussion (or debate as it had turned into) themselves with minimum input from the adults. After many hours of disputing, we reached a consensus by voting and prepared a summary of our discussions to present to the rest of the groups.

After a much needed lunch and the reporting of group views, soapbox style had begun. For those unfamiliar with the term, 'soapbox' gives an opportunity for anyone with anything relevant to say in regard to the issues discussed. They have only a few minutes to share their thoughts with everyone.

A mock referendum was held with the question being put forward 'A century later can we still say Federation was a good idea?' The State Electoral Office ran the process. The results were: 102 "yes", 1 voted "no" and the remaining were invalid votes. If only all referendums were as easy as that!

The final communique was then voted on once again with a clear majority, and then the toughest part of the day: the vote.

Students were each given one vote, in which they are asked to vote for 6 students in order of preference of whom they think would be worthy of attending the National Convention held in Melbourne. I thought it was a hard decision, considering that all the delegates that were voted the best were in the metropolitan convention. It also felt a lot like the TV series "Survivor" knowing that your vote was important, that someone had to leave, and it could be you.

Luckily I was one of thirty chosen from the NSW convention to represent both the State and Fort Street in the National Convention being held next year in March.

The experience was incredible, and I have learnt a great deal during the process whilst still being able to have fun and meet new people along the way. It is unfortunate that these conventions were only set up leading towards Australia's Centenary of Federation and will not continue in the years to come, because I know that a lot of students would have liked to have been involved in such a great activity.

Belkis L Merceles

Michael Kirby's Book Launch

On Thursday 17th of August 2000, five of Fort Street High School's Year 11 Legal Studies students were fortunate enough to take a day trip to the New South Wales Parliament House to attend the launch of Justice Michael Kirby's book "Through the World's Eye". Dip Hor, Belkis Mereles, Keith Tang, Wendy Tu and Michelle Wood accompanied by Ms. Johanson, were greeted with warm smiles and sparks of curiosity as speakers, guests, media, politicians, lawyers, teachers and various other people waited in participation for the revelation of this tremendous book.

The unveiling was hosted by Meredith Bergmann, the President of the Legislative Council who is also the mother of a fellow Fortian. She then introduced Dr. Barry Jones, the former Minister for Science, a good friend and colleague of Justice Kirby, who provided anecdotes, comments and a history of the book. Dr. Jones also mentioned how perfectly the artist Ralph Heimans captured the notorious "irritated" look of Mr. Kirby on the front jacket of the book.

Finally, it was Justice Kirby's time to speak, he welcomed and thanked everybody for attending the day and to our delight he graciously recognised us as fellow Fortians. Fort Street High School past and present united as we met ex-fortians, parents of ex-fortians, Justice Kirby himself and, most memorably, the former Prime Minister Gough Whitlam.

Comically, Mr. Whitlam had a word or two to say about some other Fortians... (Sir John Kerr). Altogether the day was a great experience and we will never forget the glamour and prestige of having been "a part of history". Many thanks are expressed to Ms. Johanson for organising the day and taking her time to give us this opportunity.

Justice Michael Kirby's book is a compilation of essays which deal with the modern controversial international issues such as sexuality, genetics, information technology, judicial activism etc. "...Michael Kirby has demonstrated that law really can be of help. He shows this time and again in the chapters of a book which makes you proud to be a lawyer..." – Geoffrey Robertson QC. This book has been most inspiring for lawyers, politicians as well as for those not involved in this profession.

In the words of Michael Kirby himself, "Once we saw the issues and problems through the prism of a village or nation-state, especially if we were lawyers. Now we see the challenges of our time through the world's eye."

Wendy Tu

**Photographed at Parliament House:
Back Row: Ms. M. Johanson, Wendy Tu,
Belkis Mereles and Keith Tang.
Front Row: Michelle Wood.**



CHESS 2000

Fort Street has had an eventful millennial year in chess. We entered one senior, one junior and two intermediate teams in the interschool chess competitions. After facing the heavyweights of chess, Trinity College, and braving the ordeals of public transport, our teams have come through with much success.

Intermediate Team 1, was highly successful. They won their division after a spectacular showdown with Trinity Grammar. The team went on to contest at state level where they came second by the narrowest of margins. An outcome truly worthy of our praise. Likewise, our senior and junior teams achieved second in their divisions against Trinity.

Whilst playing in schools like St. Pat's, we understood the federal funding furore with the Private schools. Some of the schools we visited were literally as large as small towns, occupying both sides of the road. Consequentially, we often had trouble trying to locate the chess room.

Sincere thanks go to Mr. Neil Jennings, who somehow managed the transport arrangements for four different teams and always provided afternoon tea for home games. Food and drinks rarely lasted until our guests arrived.

The year's play has revealed the chess prowess of the intellectual giants such as: -

Michael Yu, David Vadas and Edwin Ma. The very promising talent of the Year 7 Junior Team has ensured a healthy future full of potential in the Chess Championships for Fort Street. We are certainly looking forward to their exciting victories next year.

OUR TEAMS

Senior Team

Mithilesh Dronavalli ©
David Vadas
Adrian Boscolo
Chapman Yu

Intermediate Tm:1

Michael Yu ©
Kevin Wang
Wister Wu
Ping Je Pan

Junior Team

Nathan Wong ©
Xuan Ye
Gokulan
Karunasaladeva
Paul Lee

Intermediate Tm:2

Edwin Ma ©
Jack Wu
Jimmy He
Tommy Chen
Stephen Bernard
Colin Ding

Mithilesh Dronavalli

**Lunchtime: Students hone their skills.....Let the contest begin...
Edwin Ma, Nguyen Khuu,
Lean Shen, Stephen Luc.**



FORT STREET IN FRANCE

On the 23rd of June, 2000 a group of 29 people and two teachers made the long and arduous trip from Australia to France. The tale of how we arrived at our accomodation is a tale in itself, with two separate incidences of International flights being held up on account of misplaced or invalid tickets, climbing aboard the TGV on the wrong carriage and becoming lost on the final bus trip. The Year 11 students were to stay in La Petite Briche, a bed and breakfast property which was later affectionately referred to as 'The Homestead'. While Year 10's proceeded on to their accomodation, The Equestrian Farm which was later dubbed 'The Ranch'. We spent the first day sitting around and becoming accustomed to our new home, or in my case as an alien, zombie falling unconscious pretty much mid-sentence three hours later.

The second day was very relaxed, with most of the time spent eating, sleeping and recuperating. Some of the more adventurous students decided to go horse riding. We saddled up and set out with a couple of French student guides, many were of a similar age to ourselves. During this ride some people tried (with surprising success) to engage the French locals in conversation. Stephanie and Minna decided to prove.....what goes up must come down...in a rather dramatic fashion.

The third day we spent with a trip to the local high school Savigne-sur-Lathan. At first the situation was the usual...them and us. French on one side of the room, Aussies on the other. However, a game of soccer at lunchtime seemed to break the ice. Australians plus one French guy V's about three times our number. We also spent time in the classroom learning a famous French song - something about a priest who spent his time looking up ladies skirts and seeing 'all the colours of a rainbow'. A little bizarre I guess. It must be a cultural thing? Non?

Day four was the first day we spent really exploring the local scenic spots. We travelled to the ancient castle of Chinon which overlooked a town that was proudly built before Captain Cook was even born. The castle-mansion Azay-le-Rideau and its surrounding gardens plus Langais (by which stage we were exhausted). Zzzzzzz's!

The following day, we took a brief trip up to a thousand plus years old church, a slightly more extended trip to Samur, which was called the Chateaux-Musee (museum castle).

For the next few days we took the opportunity to relax. We made a nine course meal, cooked a barbecue for visiting French students and went on a couple of swims with inflatable rafts, doughnuts and alligators in an artificial lake located about an hours walk away. We went horseback riding to another castle and trotting there and back left many a student with chaffed sore thighs. Several students decided to spend the night sleeping out under the stars. This feat impressed neither Dotti nor our hosts who were somewhat distressed about the condition of the sheets we were using.

Our stay at La Briche started off with some beautiful weather that we had expected for most of our stay there. We walked to a nearby village for lunch, passed a farmer's fields which were littered with what appeared to be shot gun casings. We returned to La Briche for a final pack up and farewell. Then left for our new home at Tours.

The youth hostel we were staying at had a common room containing a pool table, a *football* table and a table for playing a game similar to air hockey. The pool table had an interesting variation which was: once the white ball was sunk, it stayed sunk. This sparked a number of arguments with a youth hostel worker, who was one of the few really rude people we met. The two highlights of Tours were the trip to Chenonceau and actually watching the bicycle 'Tour de France'. Chenonceau is a truly spectacular castle that is built across a river, surrounded by beautiful gardens. A few of the more adventurous students hired a row-boat and rowed around and underneath the castle.

The Tour de France was a bit of a let down. Early in the day, basically all of Tours had been divided in two by temporary fencing. This made travelling around extremely difficult as there were few places to cross from one side to the other. The rest of the time in Tours was spent shopping and exploring. The day after the Tour de France, we packed our bags for our last trip to Paris.

FORT STREET IN FRANCE

We entered Paris just after it started pouring rain. Wet and tired, we stumbled out of the underground Metro and after some argument we managed to find our new accommodation. We spent most of the day indoors, waiting for the rain to abate and settling into our spartan rooms. At about 8.00pm (still light-during our stay it rarely got dark before 9pm) we went for a walk to familiarise ourselves with the area. After a late dinner, we returned to the hostel.

Something interesting to note is that the small gardens dotted around the plaza in front of the church are full of either mice or rats. These rodents seem to have an adverse effect of one or two students, who decided they could do their waiting some distance away from the Church.

Other places we visited included Museum D'Orsay, an old train station that has been converted into an enormous art gallery. We spent some hours there, looking at famous works of art by such masters as Van Gogh and Michaelangelo.

We had a quick lunch and then descended into the catacombs at underground level where excavated bones of overfilling church graveyards are kept. Neatly stacked piled of bones each head height, stretch back three or more metres and wound in a twisted passageway that takes a good 10 - 20 minutes to walk at a fast pace. The architects of this rather grisly scene had created patterns and shapes in the bone walls using skulls and femurs.

The Pompidou centre is a rather ugly building that is something like the Powerhouse Museum and an art gallery combined. There were two floors of contemporary art and a Picasso exhibition on another. The view from the top was magnificent. That night we spent at the foot of the Sacre-Coeur, a church that overlooks all of Paris. An extraordinary view. The following day we went to Disneyland, and spent a day enjoying all the rides therein. A true credit to theme park engineering, no less than three rides broke down while we were on them or waiting in line for them.

Further trips included the Louvre, L'arc de Triomphe (with it's unique traffic system), shopping, Les Invalides, the Bastille day party (like a riot) and parade, a trip to a cemetery where famous people are buried, a mosque, a fountain filled with detergent and some climbed the Eiffel Tower.

When we arrived at the airport for our return trip, it was four o'clock in the morning. The computers had broken down and so our boarding passes from Amsterdam to Sydney could not be given to us. They gave us our boarding pass to Amsterdam and told us to get our other boarding pass upon arrival there. The computer failure had already held up the flight and we had a narrow window of about an hour between the arrival of our flight in

Amsterdam and our departure flight. As soon as we arrived Dotti went straight to wait in line to get our boarding passes from the appropriate desk. The rest of us either collapsed in the waiting room chairs or wandered around the airport, depending on how much sleep we had gotten the night before leaving. Ten minutes before our flight was due to depart and Dotti had barely moved in the line. Neil and Dotti decided enough was enough. They rounded everyone up and herded us towards the departure terminals, still without our boarding passes. A loud argument ensued, as it turned out our tickets had already been resold!

We were led to another waiting room where we collapsed once more as Neil and Dotti were escorted to meet with the KLM airline officials they had demanded to see. A few of our group were crying, a few were laughing over the stupidity and a few were too tired to really notice. We waited in the same waiting room for 4-5 hours before Dotti made an heroic re-entrance. The KLM officials had been disgusted with the way we were treated and gave us all meal vouchers and phone cards so that we could get something to eat and let our parents know of the difficulties. KLM had no direct flights to Sydney for some days so they booked us on a flight to Singapore Airport after which we would fly Singapore Airlines back to Sydney. This flight was due to depart in 9 hours after our original flight was supposed to. So we still had plenty of time to burn. We amused ourselves with gameboys, further exploring the airport, wheelchairs and eating enormous quantities of the food vouchers earned us.

We eventually boarded the plane and the majority of us slept on this leg. Once arriving in Singapore we still had another 9 hours before the final flight home. Fortunately Singapore airport is huge and has plenty of facilities for tired travellers, such as a timezone, showering facilities, a small movie theatre, a small science area not unlike the Power house museum and a wide variety of duty free stores. The 9 hours passed fairly quickly and then we boarded the final flight home.

The flight itself was fairly uneventful and we were all very much relieved to be back in Australia at last. But our problems weren't over yet, with the sniffer-dogs stopping in front of several of our number, who were obliged to have their bags searched. Those bags that were actually there: a fair few had been "misplaced". In fact according to the airports computers they were in Malaysia. We finally got through customs, and were reunited with our families again.

Nick Keilar Year 11.

FORTIANS HELP THE SALVATION ARMY



**Walter Chavez, David Wu & Greg Howe
With some of the student collectors.**

Charity Minded Fortians

Fortians do work hard when it comes to giving. On a cold Sunday morning in May last year a group of dedicated caring students arrived at Fort Street. The time was 7.30am! The Salvation Army Officers were waiting with a barbecue and drinks for the early risers.

Groups were formed, areas designated, collection materials handed out, all preparations were made for the charity drive in the Petersham area common to our school precinct.

Imagine my delight when I received the news from The Salvation Army that Fort Street High students had surpassed our previous year's record by miles! But the real icing on the cake was we had outstripped other schools in our region. The students collected \$3,000!

Congratulations to the following students for dedication and fortitude.

Isabel Aradas, Nicholas Bryant-Smith,
Erin Carolan, Judy Ka-Ling Chan
Walter Chavez, Marie Chew, William Dang,
Laura Fairbourn, Charles Forrester,
Martin Hartley, Greg Howe,
Chris Jessup, Andy Kirszman, Nikhil Kulkaarni,
Belinda Leary, Jonathon Lee, Robert Lee,
Jundir Liew, Jun-Guang Liew, Matthew Loh,
Paddy Lunney, Flynn Murphy,
Amelia Murray-Long, David Ng, Nick Osborne,
Venetia Robertson, Leo Sek, Goldia Shum,
Joanne Stacey, Philip Thai, Jake Wallace,
Amber Wilcox, David Wu, Rui Yi, Ker Zhang.

Well done, I'm proud to know you and appreciate your efforts. The Salvation Army were extremely pleased with your efforts.

**Ms. J. Thornhill
Co-ordinator**



ROW 4: Davy Cai, Raymond Li, Andrew Wang, Lily Wang, Peter Li, Fu Zhu, Ben He.
 ROW 3: Jingya Song, Grasancia Chung, Jessica Chen, Marina Chen, Shirley Chen, Rose Wang, Fiona Wu, Jenny Liu
 ROW 2: Alex Toh, Owen Tong, Sam Xu, Hunter Wang, Alexander Banh, Bing You, Chau Tran, Jenny Ly, Lily Zhang,
 FRONT: Carrie Yang, Vivienne Tran, Nadia Wong, Annie Dou, Mary Wang, Mandy Leung.



ROW 4: Gokulan Karunasaladeva, Angus Shum, Xuan Ye, Navi Singh, Matt Collins, Richard Christie, Chance Waters
 ROW 3: Robert Ma, Shelly Li, Hannah Allsopp, Beryl Wen, Pauline Malolepszy, Lucy Hartley, Jema Jang, Nicholas Bryant-Smith,
 ROW 2: Steven Yiangou, Paul Lee, Nathan Wong, James Stergiou, Phillip Kim, Christopher Mulligan, Kevin Tu.
 FRONT: Adi Fink, Stephanie Cairns, Anna Mackiewicz, Jessica Farr, Elizabeth Helstrom, Laura Fairbourn, Amelia Murray-Long,
 Alex Djurichkovic.



ROW 4: Ramanan Chandrobalan, John Lin, Felix Hang, Lacrimiora Nacu, Alexander Dacre, Brendan Elliott, Dean Campbell.
 ROW 3: Damian Fox, Emma Neurath, Alina Kozlovski, Anastasia Gladushchenko, Erin Carolan, Rebecc Diep, Darcy Gilling.
 ROW 2: Andrew Tran, Raphael Dixon, Jonathon Ho, Nicholas Lupi, Lillu Dronavalli, Julian Hui, Jeremy Cheng, Claire Hill, Happy Chan.
 FRONT: Gemma Valpiani, Svetlana Monastyrsky, Nina Wilkinson, Asako-Sophia Clonaris, Viet Nguyen, Jessica Do.



ROW 4: Michael Ning, Maciej Slusarczyk, Benjamin Rodrigues, Steven Ung, Michael Vote, Adit Gauchan, Owen Nanlohy.
 ROW 3: Edmund Choy, Abhirami Kannan, Margaret Colville, Anna Ko, Philippa Janu, Bernadette Cajigal, Jeremy Rubel.
 ROW 2: Angus Lau, Craig Chen, Jess Hollingworth, Alex Stanley, David Nguyen, Ben Murphy, Steven Lee, Julia Burrell,
 FRONT: Venetia Robertson, Phoebe Finch-Martin, Miriam Waks, Aimee Lee, Kara Grimsley, RoslynPhung, MarinaKoman.



ROW 4: Rory James, Eric Tran, Raymond Luu, Kieran Owens, Rommel Caguerra, Joshua Haidinger, Simon Theobold.
 ROW 3: Krishanth Kularajah, Tim Haggar, Tatjana Korecki, Abby Wallace, Clara Chung, Daniel Van, David Sahota.
 ROW 2: Allan Chain, Steven Hua, Paul Dutkowski, Dan Crook, Vinh Lam, Shannon Ko, Bob Tran.
 FRONT: Sandy Yao, Anna Kopyciok, Jenny Chang, Bridie Drummond, Hannah Contziu, Michelle Sutton, Deanna Borel, Alayna Walsh.



ROW 4: Weiqi (Ricky) Meng, Sae-Il Pak, Justin Siu, Robert Shi, Steven Wong, Philip Thai, John Park.
 ROW 3: David Le, Hyun-Sin Kim, Catherine Ye Lin, Ann Khuu, Jenny Du, Nancy Shen, David Mao, Lin Wang.
 ROW 2: Jason Ho, Keith Ng, Christopher Tran, Joe Xie, Derrick Tsui, Paul Hua, Terence Chan.
 FRONT: Vivian Nguyen, Christine Lu, Joyce Chan, Alison Wu, Mary Chan, Irene Gao, Susan Su, Tracy Wong.
 YEAR: 8F



ROW 4: Nishad Kulkarni, Daniel Ryan, Alfred Tao, Daniel Lambert, Daniel Courtney, Jason He.
 ROW 3: Ming Li, Edmund Sullivan, Aviea Renouf, Natalie Millar, Bronwyn Overs, Jaspreet Singh, Daniel Morrison.
 ROW 2: Thomas Koch, Benjamin Ha, Aditya Bhagwat, Daniel Chan, Igor Petkovic, Thuvarakan Thanapalasuntheram, Kenneth Yuen.
 FRONT: Vicki Lowe, Nina Frishling, Amber Wilcox, Angela Wallace, Julia Chen, Sophie Kaplan, Monica Awad.



ROW 4: Kingsley Drew, Andrew Qiu, Nicholas Tan, Ben Osland, Ken Finis, Steven Shi, Jonathon Lee.
 ROW 3: Aaron Birks, Christopher Jessup, Alison Kaye, Feiyi Zhang, Elwin Cross, Clare Russell, Jun-Guang Liew.
 ROW 2: Gavin Chan, Ryan Chiu, Douglas Park, Kevin Siu, Daniel Yagoub, Kosta Tzioumis, Flynn Murphy.
 FRONT: Wendy Lu, Zara Fox, Mystery Bernal-Deller, Diana Herwono, Tracey Phan, Masha Matousovskaia, Monica Runiewicz.



ROW 4: Adrian Ng, Steson Lo, Ling Ti Chen, Renata Popenhagen, Jake Wallace, Tom Elliot, David Shen.
 ROW 3: Nikhil Sreeguriraju, Leo Boudib, Nirushan Raveendiran, Jessica Brewster, Shahrooz Chowdhury, Daniel Kiat, Milton Lai.
 ROW 2: Christopher Cotterill, Nick Whitehead, Paul Chan, Peter Valpiani, William Rossiter, Karthik Ganesh, Nicholas Leung, Akaash Yao.
 FRONT: Meg Farrington, Charlene Ko, Eve Hood, Jenny Ma, Amy Nguyen, Alex Darby, Sarah Russell.

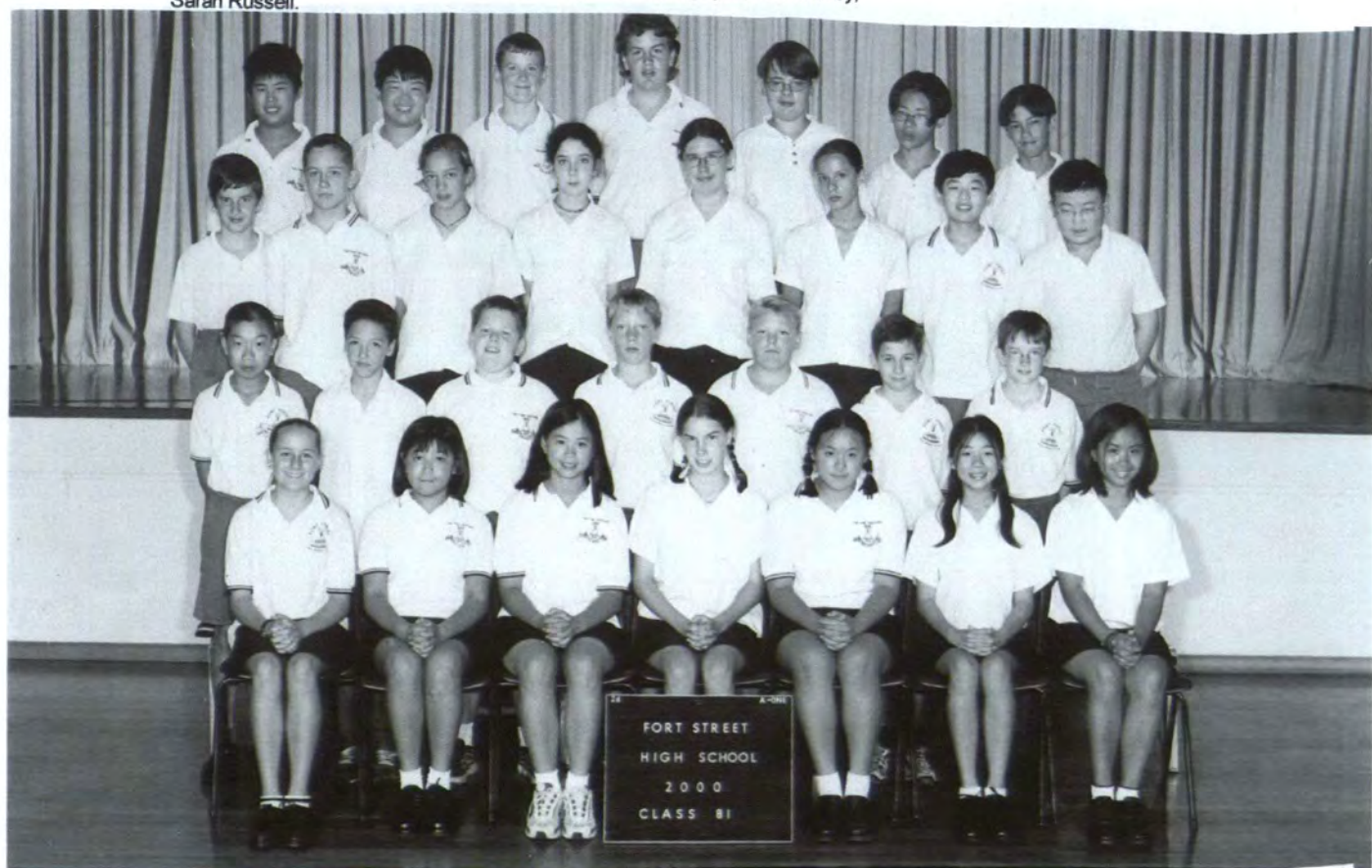

ROW 4: Adrian Chan, Danny Tauv, Luke Owen, Liam Whiting, Roland Kiel, Tony Lam, Nicholas Grandjean-Thomsen.
 ROW 3: Stuart Rollo, Daniel Sullivan, Bowie Raffan, Anna McDougall, Kristina Erzkov, Vana Makaric, Peter Shi, John Yue.
 ROW 2: Andy Fung, Samuel Thorne, Fergus Montgomery, Gregory Lewis, Chris Collitis, Vukasin Vujasinovic, William Wallace.
 FRONT: Beth Goldfinch, Aimee Chau, Sarah Kwok, Nadia Vitlin, Dariya Kaing, Lisa Nguyen, Reichelle Carson.



ROW 4: Jack Wu, Peter Callender, Jack Marshall, Gareth Douse, Greg Waddington, Enoch Lau, Cal McGuirk.
 ROW 3: Lucy Geremin, Wayland Le, David Wu, Bethany Lalor, Alex Spiers, Daniel Forinash, Addison Ma, William Figgett.
 ROW 2: Shaw Kamada-Laws, Terry Yuan, David Dziedzic, Stephen Hagggar, Paul Liu, Joven Demonteverde, Paddy Batchelor.
 FRONT: Chiara Bianchino, Vita Gray, Jessica Brooks, Michaela Pollock, Melissa Ellingworth, Kate Scott-Murphy, Lucille Verdey, Angela Diec.
 YEAR: 9F



ROW 4: Matt Jarman, Wister Wu, Max Schollar-Root, William Hey-Cunningham, Varun Sahni, Matthew Lee, Brendan Markey, Minbo Wang.
 ROW 3: Peter Luan, Johnson Gao, Amy Bao, Christina Lam, Anna Lucewicz, Michael Li, Kevin Ha.
 ROW 2: Rabbi Ahmed, Robin Wilkins, Sunny Li, Tim Lam, Jacob Fry, Daniel Tse, Benjamin Yuen.
 FRONT: Virginia Tang, Katherine Turner, Kathy Nguyen, Lillian Lau, Kavita Bedford, Margaret Park, Imelda Daniel, Belinda Lu.



ROW 4: Ben Zhao, William Wong, Vesna Trobec, Martin Hartley, David Jiang, Luke Vu, Andrew Diong.
 ROW 3: Gary Chen, Steven Quinn, Claire Cherrington, Albert Lee, Lucy Zou, Ty Wood, Jess McGuirk, Shinuo Liu.
 ROW 2: Michael Thorne, Sam James, Mirza Nurkic, Matthew Fordham, Devesh Sharma, Thuan Ho, George Hu.
 FRONT: Stephanie Wong, Qian Yu, Caroline Zhou, Priyanka Rao, Jenny Choi, Alex Parker, Claudia Husin, Ruby Chiu.



ROW 4: Boris Kresic, Zane Ma, Daniel Lavelle, Jonathon Hardgraves, Kevin Wang, Johnny Zhang, Geoffery Duong.
 ROW 3: Ping Jie Pan, Max Wang, Tina Nguyen, Ara Ko, Rachel Xu, John Nguyen, Ryan Reynolds.
 ROW 2: Eric Cheung, Garry Chang, Jin Ju Soung Choi, Simon Sheikh, Jim Ding, Iwen Chen, Jeffrey La.
 FRONT: Belinda Tran, Vina Xiao, Jenny Lin, Louise Sun, Jennifer Ahn, Jessica Zhang, Meg He, Judy Tu.



ROW 4: Wayne Pan, Bob Jang, Patrick Lunney, Grant O'Donnell, Nicholas White, William Lee, William Leung.
 ROW 3: Benjamin Ryan, Angus Jen Tiet, Janet An, Ava Lam, Alix Nicholson, Sameer Chowdhury, Christopher Bu,
 ROW 2: Fahim Ahmed, Arun Nadesan, Jonathon Chau, Ming Ren, Timothy Sam, Steven Luc, Supratik Ray.
 FRONT: Tracey Ying, Jenni Gray, Jacqueline Parker, Susannah Ivory, Amelia Roberts, Neha Goel,
 Sheryl Soo.
 YEAR: 10R



ROW 4: Frank Tao, Stephen Chau, Anurag Verma, Alex Nikoliouk, Karthik Ramakrishnan, Jimmy He, Vincent Chu.
 ROW 3: Davy Lei, Ren He, Boyu Zhao, George Ng, Chris Kang, Kevin Tran, Edwin Ma.
 ROW 2: Matthew Wong, Brian Diep, Grace Chan, Alex Stuart, Howard Cheung, John Bui, Jay Kathavate.
 FRONT: Anisha Gautam, Susan Hoe, Alice Qian, Nikki Peng, Vanessa Tran, Louisa Li, Yi Wang, Clare King.

YEAR: 10T



ROW 4: David Kwok, Jackson Trieu, Aniket Mulherkar, Zuo Huang, Vineeth Chippada, Josh Moriarty, David Schaverien.
 ROW 3: Jinyang Qian, Haily Nguyen, Angela Wen, Alannah Schumann, Harriet Johnson, Shruti Kulhallii, Melissa Lee, Robert Bautista.
 ROW 2: Michael Yu, Geoff Lai, David Campbell, Fabio Lombardini, Brodie Cullen, Gregory Howe, Jason Chan.
 FRONT: Teresa Choi, Eileen Xie, Jane Fan, Divija Paramatmuni, Hoiing Ngai, Gina Dang, Nori Dimaculangan, Jensyn Luc.
 YEAR: 91



ROW 4: David Haines, Nick Findlay, Andrew Birdsall, Igor Butorac, Chris Gilbert, Rory Dufficy, Stephen Bernard.
 ROW 3: Alfred Lin, Michael Nguyen, Prasanth Ramkumar, Richard Kennedy, David Wu, Neeraj Aggarwal, Felix McIntyre.
 ROW 2: Allan Sun, Tommy Chen, Louis Huynh, Marianne Moroney, Zafir Siddiqui, Felix Hong, Nicholas Yuen.
 FRONT: Zaine De Souza, Sunhae Oh, Naomi Ben-David, Marian Lesslie, Alisha Wong, Ann Tsuei, Flora Chao, Julianna Dang.
 YEAR: 101



ROW 4: David Collits, David Helstroom, Derek Yeung, Ben Prest, Colin Ding, James Wang, Lachlan Gauke, Edward Byun.
 ROW 3: Nguyen Khuu, Simon Lo, Marc D'Amici, Nicole Sutton, Thomas Huynh, Anton Trees, William Brook.
 ROW 2: Gary Leung, Toby Sinclair, Hagen McCaig, Daniel Do, Howard Yean, Alfred Shiu, Peter Hoang.
 FRONT: Janelle Espinas, Emma Williams, Sarah Ho, Juliette Mitchell, Phoebe Haylen, Nina Pollock, Shaily Aggarwal, Hannah Kim.
 YEAR: 10F



ROW 4: Simon Johnson, Andrew Ta, Leon Shen, Viktor Frankowski, Matthew Clarke, Tom Radford, Alex Bryant-Smith.
 ROW 3: Lee Mathason, Geoffrey Stewart, Emily Irvine, William Nguyen, Ellen Lee, Timothy Osland, Karol Florek.
 ROW 2: Jordan Delaney, Leigh Cartwright, Patrick White, Kyo-Soung Choi, Joshua Augustinus, Brendan Reeks, Jose Ruaya.
 FRONT: Catherine Santangelo, Helen James, Caroline Grandjean-Thomsen, Elsie Chen, Laura Corney, Sahra Behardien, Cheryl Tan.
 YEAR: 100



ROW 4: Gary Ching, Khang Bui, Matthew Clark, Louis Couttoupes, Mark Barber, Sean Caritt.
 ROW 3: Marcus Coleman, Sudhanshu Bhardwaj, Zoe Andreeva, Julian Boyce, Alex Bocking, Vincent Cakic, Ye Chuah.
 ROW 2: Reegan Barber, Aaron Chang, Eve Blayney, Alex Ardino, Rocky Bhardwaj, Jeremy Chia.
 FRONT: Soo Bahk, Jessica Ciatworthy, Jessica Au, Carmen Chan, Leanne Chen, Haomin Chen Alice (Ying) Chen.
 YEAR: 11F



ROW 4: Duc Ho, Lee Dewane, Reece Hinchcliff, David Emerson, Joel Heenan, Tom Keenan-Brown, Jeffrey Fong.
 ROW 3: Otto Dargan, Eamon Fenwick, Angela Herscovitch, Arwen Cross, Laura Hartley, Nick Kellar, Matthew Jophnson.
 ROW 2: Douglas Kerle, Harry Hu, Methilesh Dronavalli, Dip Hor, Gaurav Johri.
 FRONT: Vicky Kan, Sharon Jia, Kate Goudie, Mandy Huynh, Lina Jang, Natasha Goh, Elian Fink, Julie Jeong.
 YEAR: 11O



ROW 4: Parnel McAdam, Yohan Kim, Dominic Lo, Michael Moroney, Joseph Lee,
 ROW 3: Andrew Lee, Kyung Whan Kim, Xavier McKenzie, Shannon Lardi, Joanna Lin, Richard Logge, Philip Ma.
 ROW 2: Colin Lam, John Lee, Brendan Lee, Ye Chuah, William Le, Lucas Liang, Phi Luu.
 FRONT: Elaine Kwan, Anh-Thu Le, Ji-Young Lee, Stephanie Low, Belkis Mereles, Ping Lin, Sarah Lau.
 YEAR: 11R



ROW 4: Trumper Raffan, Simon Rodwell, Joseph Ni, Jordi Rudelle Greig, Morgan Renew, Siddharth Raja.
 ROW 3: Menaka Sirisena, Guy Ragen, Marcus Coleman, Holly Philip, Jacob Sauwick, Ashley Newman, Prashan Ratnakumar.
 ROW 2: Martin Nguyen, Alvin Savoy, Andrew Sedlacek, Jinny Oh, David Newell, Benjamin Poon, Alexander Nicholas.
 FRONT: Anushka Paul, Ella Pong, Thi Nguyen, Eileen Saekang, Paris Ramrakha, Elsie Ngo, Tiara Relativo.
 YEAR: 11T

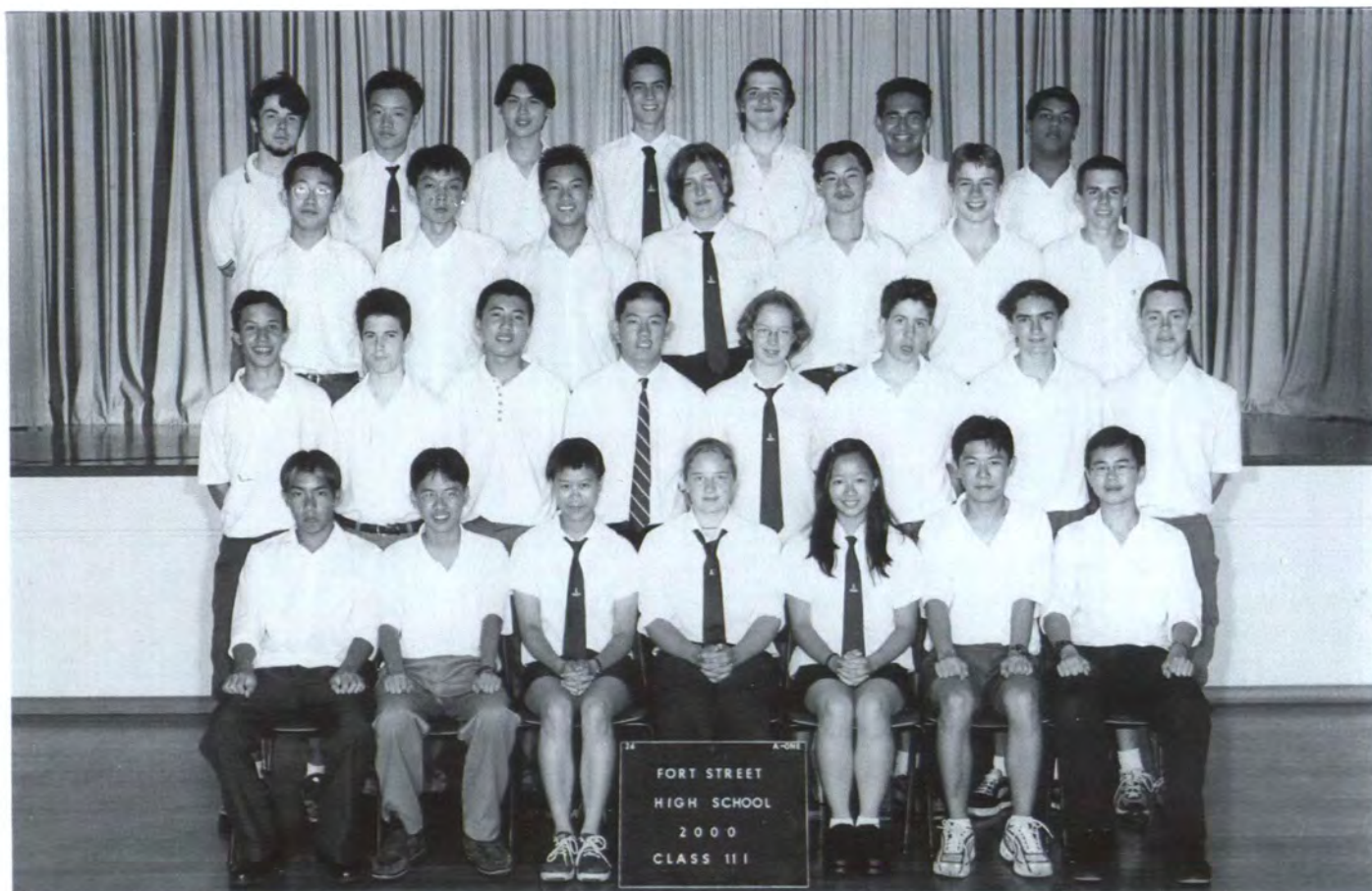

ROW 4: James Short, Nelson Trieu, David Sun, Damian Thomas, Tom Stephenson, Niven Vanmali, Viknesh Vijayenthiran.
 ROW 3: Alan Shen, Stephen Tran, Charles Tran, Basia Slusarczyk, Simon The, Adam Thwaites, Ben Toupien.
 ROW 2: Jeremy Sung, Reegan Barber, Joseph Tran, Perth Tsang, Lauren Tarr, Parnel McAdam, Gerrard Serisier, Michael Tromans.
 FRONT: Liam Tong, James Tran, Pamela Tran, Monika Tice, Wendy Tu, Vincent Tang, Keith Tang.
 YEAR: 11I



ROW 4: Sam Waks, James K. Wright, Vedran Vulovic, Clancy Yeates, Alexander Vitlin, Cheng Xin Yang.
 ROW 3: Chapman Yu, Peter Wu, Sarah White, Chela Weitzel, Anna Zhu, Brandon Zhu, Pat Yu.
 ROW 2: John Williamson, Michael Wong, Tony Zhu, Arif Zaffer, Tyron Wong, James Wong.
 FRONT: Jacqueline Wong, Yi Ching Zhao, Susan Wang, Haidee Wong, Joanna Ji Woo, Anna Zhang, Michelle Wood.
 YEAR: 11A



YEAR 12 2000

- ROW 8: Tim Davidson, Dan Bishton, William Dang, Marcus Hayward, Christopher Paraskeuopoulos, Nicholas Dixon-Wilmshurst, Jonathon Murty, Lachlan Delaney, Damjan Vlastelica, Joel Bedford, Kevin Pickett, Philip Mayger, Matthew Scott, Alan Gao, Peter Hey-Cunningham, James Shine, Tom Irvine, Xuan Pham, Zac Wolfson.
- ROW 7: Robert Lee, Maurizio Stefani, Nicholas Falkinder, Marc Howlin, Christian Lee, Nicholas Osborne, Chris Son, Piotr Bozym, Thomas Dallow, Gareth Ivory, Robert Lawson, Steven Turner, Phong Le, Alok Abraham, Adrik Kemp, Maher Safi, Michael Lee, Philip Clare, Rocky Lam.
- ROW 6: Elizabeth Lee, Clara Rolls, Natalie Green, Julia Britton, Francisca Gan, Nancy Jiang, Verity Gill, Sascha Morrell, Ruth Jago, Sarah Steel, Sarah Dearne, Zoe Lyon, Georgina Morris, Tamara Pearson, Keely McNamara, Elaine Chui, Holly MalaQUIN, Beth Deguara, Roxana Chan.
- ROW 5: Khanh Nguyen Ma, Ho Tung Wong, Jack Yao, Charles Huynh, David Ng, Nick Forwood, Alexis Grivas, Jack Prest, Ewan McGaughey, Victor Chandra, Steven Le, Rui Yi, Kalon Huett, Liam Ryan, Kenny Scott, James Thai, Declan Kuch, Nikhil Kulkami, Charles Forrester, Tommy Tsang.
- ROW 4: Lennard Lopez, Danny Fairfax, Thomas Costa, Gavin Smith, Chris Berry, Peter James, Lee-Shaun Saw, Fei Yu, Matthew Paul, Martin Kurek, Rhys Hearne, William Vuong, Peter Paszti, Mathias Boer-Mah, Cassian Cox, Michael Fordham, Anthony Horler, Hoyan Ngai, Mark Crocker.
- ROW 3: David Vadas, Julian Curiskis, David Tran, Michelle Roldan, Margot Allan-Georgas, Judy Ka-Ling Chan, Jee Hyun Kim, Louise Dumbrell, Phoebe Singleton, Mowena Wilkins, Heather Wallace, Charmaine Tam, Camilla Holt, Kristy Green, Chih-Ping Liao, Veena Rajan, Helen Jin, Susan Cheung, David Saba, Mamun Ar Rashid, Phillip Tehong.
- ROW 2: Wilson Pok, Matthew Loh, Sumudu Jayawardana, Gonzalo Vilches, Fergus Beams, Changyuan Loh, Leo Sek, Adam Foley, Titus Hui, Dennis Singh, Jundir Liew, John Nguyen, Ben Chang, Ben Scott, Michael Lee, Vic Khalili, Ker Zhang, Bill Au, Jeffrey See.
- FRONT: Thu-Ha Nguyen, Cecilia Ng, Shelley Lin, Uma Aggarwal, My-Van Bui, Nicole Niu, Mary Lentros, Bethany Siepen, Andreea Heriseanu, Madhushini Bazil, Nancy Kim, Gohar Yazdabadi, Goldia Shum, Sindy Sheu, Jingling Li, Jocelinn Kang, Alexandra Arneri, Betty Chang, Natalie Manning.



PEER SUPPORT

- ROW 4: Tom Keenan-Brown, James Wright, David Emerson, Matthew Clark, Louis Couttoupes, Morgan Renew, Mark Barber, Clancy Yeates, Alex Vitlin, Sean Carritt.
- ROW 3: Kate Goudie, Anushka Paul, Lauren Tarr, Basia Slusarczyk, Chela Weitzel, Holly Philip, Shannon Lardi, Natasha Goh, Joanna Lin, Elian Fink.
- ROW 2: Phi Luu, Alvin Savoy, Liam Tong, Gorav Johri, Nick Kellar, Lucas Liang, Tony Zhu, Dip Hor, Gerard Serisier, Prashan Ratnakumar.
- FRONT: Stephanie Low, Sharon Jia, Jacqui Wong, Carmen Chen, Haidee Wong, Belkis Merelis, Anna Zheng, Wendy Tu.



**Kay Johnson confers with
Peer Support Leaders**

FORT STREET HIGH SCHOOL

STAFF OF 2000



- ROW 5: Chris Moynham, Leo Sorbello, Theo Leondios, Paul Brewster, Bruce Fraser, George Rezcallah, Barry Hagerman, Michael Harding, Phil Canty, Robert Hayes, Tony Millward, John Chung, Michael Browne, Lewis Sorban, Aaron Short.
- ROW 4: Toula Bull, Dianne Hubbard, Anita Furnari, Robyn Paice, Sandra Page, Steven Velez, Colin Gaskin, Alison Wilson, Marilyn Ireland, Lynn Joslyn, Hiliare Fraser, Serge Yalichev.
- ROW 3: Jennifer Thornhill, Patricia Bresnahan, Sarah Dawkins, Judy May, Mary Stamoulos, Kay Johnson, Patricia Wardell, Marcelle Hoskins, Kristy Macdonald, Christine Egan, Louise Beevers, Sandra Albanese, Zorka Lacmanovic.
- ROW 2: John Gaal, Anne Draper, Vicki Chiplin, Mary Tracogna, Ratna Nagarajah, Tamara Kozlowska, Irene Nicholson, Kate McGown, Kim Anderson, Anne Kelly, Julie Fisher, Kerrie Weir, Zora Neurath.
- FRONT: Greg Talbot, Steve Scheduling, Tim Jurd, Debbie Miniutti, John Buckingham, Ros Moxham-Principal, Andrea Connell – Deputy Principal, Vivienne Dadour, Neil Jennings, Marie Johanson, Greg Osland, Warren Griffith.







FAREWELL YEAR 12 - 2000

AUTOGRAPHS

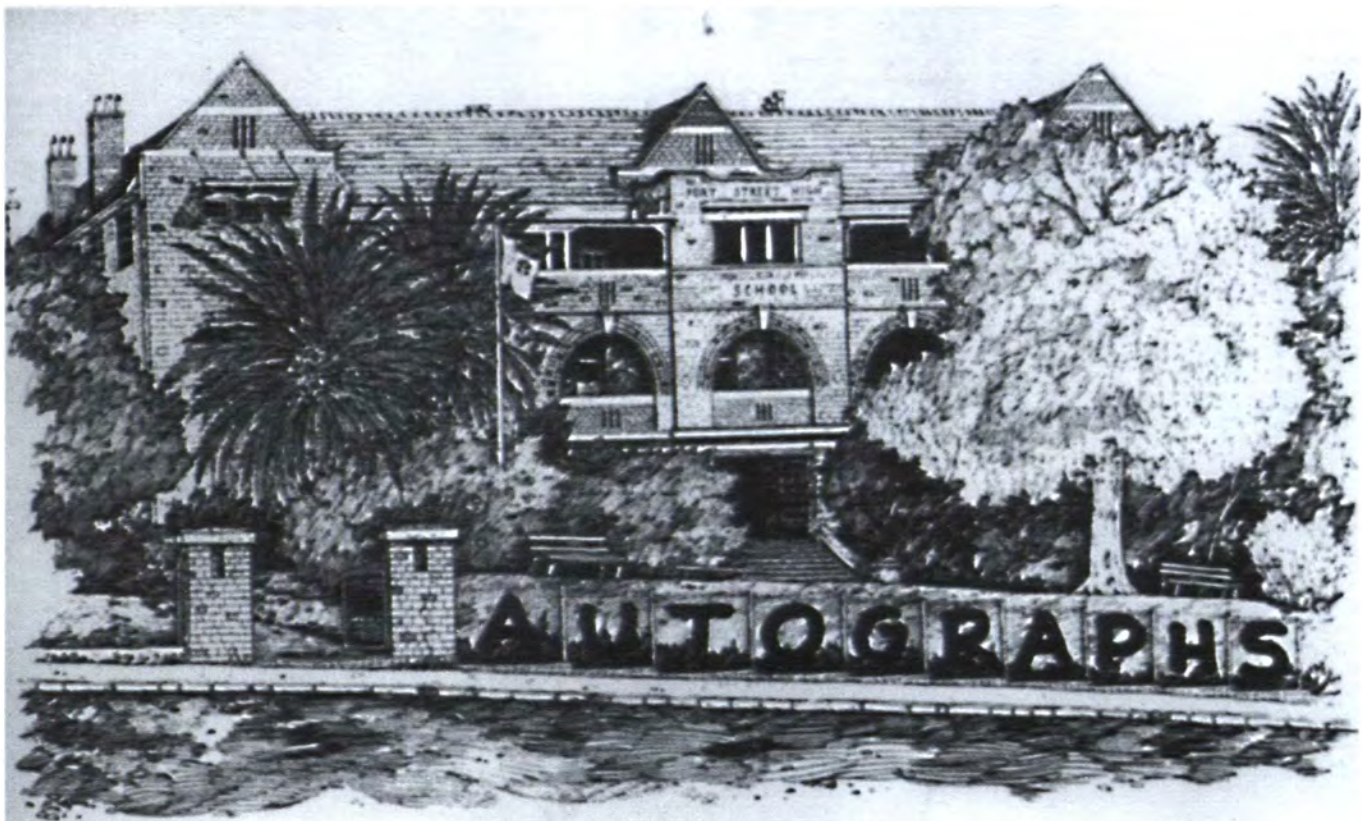

FORT STREET HIGH SCHOOL 2000

Dis. Alvin 10/20

